

# PLASTIC TEST EQUIPMENT



POLİNAR PLASTİK MAKİNE ve KALIP  
SANAYİ TİCARET LİMİTED ŞİRKETİ  
İkitelli O.S.B Eskoop San. Sit. D Blok  
No: 34 Başakşehir / İSTANBUL - TURKEY

Phone : +90 212 549 88 20 - 21  
Fax : +90 212 549 88 19  
E-Mail : info@polinar.com.tr

[www.polinar.com.tr](http://www.polinar.com.tr)

PTE (POLİNAR TEST EQUIPMENT)  
İkitelli O.S.B. Eskoop Sanayi Sitesi  
B Blok No.86 Başakşehir  
İstanbul / TÜRKİYE

Phone : +90 212 549 88 20 - 21  
Fax : +90 212 549 88 19  
E-Mail : info@polinar.com.tr

[www.ptecom.tr](http://www.ptecom.tr)

POLINAR GmbH  
THE ICON VIENNA, Tower 24  
301 Wiedner Gürtel 13 1100  
Vienna AUSTRIA

Phone : +43 (0) 1 253535 4044  
Fax : +43 (0) 1 253535 4044  
Mobile : +43 676 5983869  
E-Mail : office@polinar.at

[www.polinar.at](http://www.polinar.at)

SLIDE WÄNDLICH - 2022/03 © 0717 6170948

**POLINAR**  
*her şey çekirdekten gelişir*

# PLASTIC TEST EQUIPMENT

Quality and control  
for optimal production  
efficiency



**pte**

[www.ptecom.tr](http://www.ptecom.tr)

**POLINAR**  
*her şey çekirdekten gelişir*

**pte**

**POLINAR**  
GmbH



**pte**

[www.pte.com.tr](http://www.pte.com.tr)

**POLINAR**  
her şey çekirdekten gelişir

## ABOUT US

We are a team who had come together to give shape to every type of plastic and produce engineering solutions.

Our team of professionals possesses education of international standards and technical equipment, and is purposefully directed to produce top notch technological systems and is able to provide these systems to their customers in a manner of quality.

Our CNC machines and harnessing equipment are of high-quality and programmed with the logic of mass production.

All of the engineering solutions are discussed in the environment of computerized design and analysis in pre-production phase and our customers are served with this quality of approach.

[www.pte.com.tr](http://www.pte.com.tr)

# HYDROSTATIC INTERNAL PRESSURE TESTER



## Description

The internal pressure creep test is a test procedure for determining the strength of thermoplastic pipes. The specimens are subjected to a constant hydrostatic internal pressure at a constant ambient temperature either for a specified period or until they fail. The test duration is subject to the tension generated by the internal pressure and the temperature. It combines the tester's exceptional reliability with simple operation without making any compromises with respect to precision and flexibility.

### Accessories



### Simple and safe operation

- Convenient operation and clear visualisation via integrated touch display

### Reliable test results

- Microprocessor-controlled, with automatic failure and leakage detection
- Precision pressure transducer incl. pressure gauge for test pressures up to 60 bar and system pressure up to 130 bar
- Water disruption detection system

### Reliable test results

- High-quality unit components guarantee high reliability, a long service life and low maintenance costs
- Extendable up to 20 station on request

### State of the art technology

- Interface to BTLogger® Windows based datalogger software for reporting and visualisation.

## Basic cabinets

Pressure range up to	bar	100	100	100	100
Integrated high-pressure pump		•	•	•	•
Pump capacity	l/min	10	14	14	14
Second system pressure		-	-	-	-
Stainless steel pressure reservoir		•	•	•	•
Max. number of stations		4	8	12	16
Integrated control unit via 5.7" touch-screen		•			
Integrated control unit via 12.1" touch-screen		○	•	•	•
Compatibility with BTLogger®		From version 3.x			
Simple Burst Test		Available in 1 test line only			
CE conformity		•			
Width	mm	900			
Depth	mm	900			
Height	mm	1700			
Weight (with 12 stations)	kg	250			

### Voltage data

230/400 V, 50/60 Hz (other voltages on request)

• included ○ available / optional □ eligible - not available



### Standards

ISO 1167  
ASTM D 1598  
ASTM D 1599

# TEST TANKS for PIPE TESTING



## Description

The internal pressure creep test is a test procedure for determining the strength of thermoplastic pipes. The samples are subjected to a constant hydrostatic internal pressure at a constant ambient temperature either for a specified period or until they fail. The test duration is subject to the tension generated by the internal pressure and the temperature. The test tanks are specially designed for testing thermoplastic pipes and fittings. The high reliability, durability of the materials used and the constant temperatures in the test tank with respect to both volume and time provide particularly reliable test conditions. The efficient use of energy with low servicing and maintenance costs guarantee efficient long term operation. There are a wide range of tank dimensions and connection options, enabling the tanks to be flexibly adapted to various operating conditions.

## Accessories



### Simple and safe operation

- > Air operated lid

### Reliable test results

- > Constant test temperatures thanks to highly efficient water circulation and precise temperature control in the inner tank

### Lasting efficiency

- > High quality stainless steel test tank (AISI 304)
- > Double insulation of the basic tank and insulated lid for minimum energy loss

### State of the art technology

- > Integrated monitoring and control of test temperature.

## Versions

	T071800V1P	T071800V2P	T071800V3P	T071800V4P	T071800V5P	
Width (internal/external)	mm	750/900	1000/1500	1200/1400	1500/1800	1500/1850
Length (internal/external)	mm	1000/1400	1500/2000	2000/2800	2500/3300	3000/4100
Height (internal/external)	mm	900/1300	1300/1900	1200/1900	1500/2200	2000/2800
Height open	mm	2000	2500	2300	2800	3500
Number of manifold slots		4+4+2	4+4+2	4+4+2	4+4+2	4+4+2
Number of suspension rails (included)		-	2	2	2	2
Heating power	kW	15	15	45	60	60
Inner tank material		AISI 304				
All parts coming into contact with water stainless		•				
Water temperature	°C	Min. ambient temperature + 10/max. 95				
Water temperature adjustable in increments of	°C	0.1				
Temperature control with regulating accuracy	°C	±0.5				
Circulation system		•				
CE conformity		•				
Voltage data		230/400 V, 50/60 Hz (other voltages on request)				

• included ○ available / optional □ eligible - not available



## Standards

ISO 1167

ASTM D 1598

ASTM D 1599

# END CLOSURES for PIPE TESTING



## Description

The internal pressure creep test is a test procedure for determining the strength of thermoplastic pipes to constant hydrostatic internal pressure at a constant ambient temperature. The samples are tested either for a specified period or until they fail. The test duration is subject to the tension generated by the internal pressure and the temperature.

### Accessories



### Simple and safe operation

- Quick assembly thanks to proven end closure design
- Simple and reliable venting directly at the sample

### Lasting efficiency

- High quality unit components guarantee high reliability, a long service life and low maintenance costs

## Versions

For pipe diameter DN	mm	20-40	50-90	110-315	350-630
Maximum test pressure	bar	60	60	60	40
End closure material	Stainless steel/AISI 304/S30300				
Suitable for PE pipes	•				
Suitable for PP pipes	•				
Suitable for PVC pipes	•				
Vent screw	•				
Ring nut for suspension	•				
Pressure connection	Quick-release plug				

• included    ◦ available / optional    ◻ eligible    - not available



### Standards

ISO 1167

ASTM D 1598

ASTM D 1599

# MFI / MFR TEST DEVICE



## Description

The MFI/MFR tester combines the determination of the melt flow rate (MFI) and melt volume rate (MVR) of thermoplastic materials into one test procedure under specified temperature and load conditions.

### Accessories



#### Simple and safe operation

- Data input via touch display

#### Reliable test results

- Excellent temperature accuracy with respect to volume
- And time thanks to a self optimising control system
- Electronically controlled cutting device

#### Lasting efficiency

- Minimum energy demand thanks to timer controlled heating up times and max. temperature constancy
- Long service life thanks to high quality materials and materials resistant to high temperatures

## ➤ Versions

	°C	T061V1P
Test temperature	°C	50 to 300 in increments of 0.1 K
Temperature regulating accuracy		±0.1 K at the nozzle ±0.5 K over the entire usable length of the test cylinder
0.325-kg load weight		○
1.200-kg load weight		○
2.160-kg load weight		●
3.800-kg load weight		●
5.000-kg load weight		●
10.000-kg load weight		○
11.600-kg load weight		○
Automatic cutting device		○
Piston distance measurement unit (for determining MVR)		○
CE conformity		●
Permissible ambient temperature	°C	+5 to +30
Permissible relative humidity		Max. 70%, non-condensing
Width	mm	420
Depth	mm	420
Height	mm	700
Weight (without weight discs)	kg	40
Voltage data		230 V, 50/60 Hz (other voltages on request)

● included ○ available / optional □ eligible - not available



### Standards

ISO 1133

ASTM D 1238

08-09

www.pte.com.tr

# UNIVERSAL TENSILE TESTER



## Description

The universal tensile tester is used for performing tension, pressure or bending tests. The classic application is the tensile test. This involves subjecting a sample to an increasing tensile load until it breaks. The force-deflection diagram generated during this test provides information on the load-bearing capacity, elasticity and plastic deformation of the material sample.

## Accessories

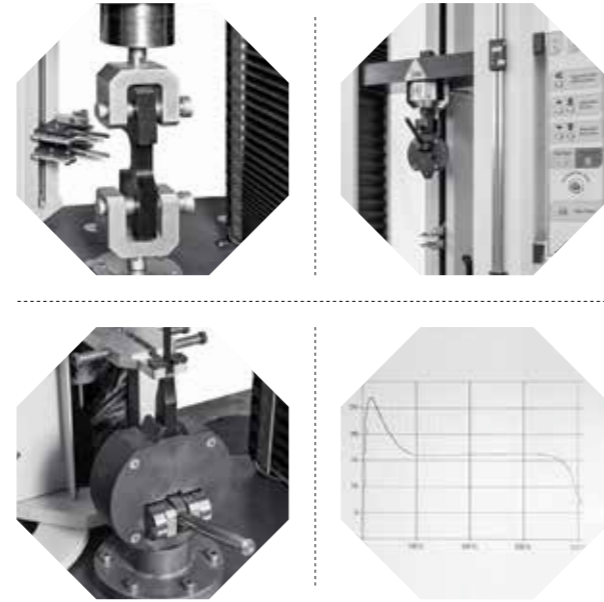

### Simple and safe operation

- Convenient operation and clear visualisation (test curves, calculations and statistics) via integrated touch display
- Easy to change the grips

### Reliable test results

- Accuracy:  $\pm 0.5\%$  of the measurement up to 1/1000 of the max. measuring range

### Lasting efficiency

- Precise, self-cleaning ballscrew with sealed, maintenance free bearings for low-noise operation
- Brushless servo motor for maintenance-free operation

### State of the art technology

- Automatic detection and calibration of load cells and extensometers
- 800% overload protection

## Versions

Test force	kN	5	20	50
Max. crosshead travel excluding grips	mm	1100	1100	980
Vertical space	mm	1275	1275	1180
Throat	mm	295	295	420
Crosshead speed	mm/min	0.001 - 500	0.001 - 500	0.001 - 500
Speed accuracy (under stable conditions)	%	0 $\pm$ 0.1		
Extensometer		●		
Wedge grips		○		
Grips for large wall thickness		○		
Peel test fixture for composite pipes		●		
Compression plates		○		
Further accessories		On request		
CE conformity		●		
Permissible ambient temperature	°C	10 to +40		
Permissible relative humidity		10 - 90%, non-condensing		
Width	mm	590	980	980
Depth	mm	450	600	600
Height	mm	1575	2250	2250
Weight	kg	156	600	675

### Voltage data

3 ph 380/400 VAC, 50/60 Hz (other voltages on request)

● included ○ available / optional □ eligible - not available



## Standards

ISO 527

ISO 6259

ASTM D 638

# CNC MILLING MACHINE for TEST BARS



## Description

The test bar milling machine enables bar-shaped plastic samples to be produced for tension, pressure, bending and flexural impact tests in accordance with a wide range of standards. The CNC milling machine is a table-top unit with electrically locking protective doors. Pre-configured machining programs for all common bar shapes and visualisation via touch screen display makes it very easy to operate the milling machine. Up to five test bars can be produced in one milling process. The all-round enclosure ensures safety at the workstation during the milling process. A swarf extraction system ensure the workstation remains clean.

## Accessories



### Simple and safe operation

- Pre-configured machining programs protective doors with safety lock
- Clean workstation thanks to machine enclosure delivered with workbench

### Reliable test results

- Test bars milled in accordance with standards
- CNC-controlled positioning of the axes
- Machined areas cooled with compressed air

### Lasting efficiency

- High-quality unit components guarantee high reliability, a long service life and low maintenance costs

## Versions

Milling table with mechanical clamping device

- Clamping range for blanks small

- Clamping range for blanks big

- Number of test bars

Milling table with pneumatic clamping device

Rotational speed of spindle

Hard metal milling cutter Ø 12-16 mm (subject to standard)

Diamond milling cutter

Industrial vacuum cleaner

Milling program

CE conformity

Permissible ambient temperature °C

Permissible relative humidity

Noise emission

Width (milling table) mm

Depth (milling table) mm

Width mm

Depth mm

Height mm

Weight kg

Voltage data

	T081V1P
	•
	Max. thickness 30 mm Max. length 220 mm
	Max. thickness 90 mm Max. length 250 mm
	Max. 2/5
	•
	Between 3000 and 18000 per minute
	•
	○
	○
	Can be selected acc. to EN, ISO, ASTM, etc.
	•
	+5 to +30
	Max. 70%, non-condensing
	85 dB(A) during the milling process
	500
	300
	900
	900
	1700
	450
	3 ph 380/400 VAC 230 V, 50 Hz (other voltages on request)

• included ○ available / optional □ eligible - not available



## Standards

ISO 179/180	ISO 16770
ISO 527	ASTM D 638
ISO 6259	ASTM D 1822

# CARBON BLACK TESTER



## Description

Statutory standards prescribe the verification of carbon black content of polyolefin plastics. The test method is based on pyrolytic decomposition of the material in an inert gas flow (nitrogen). This means that the remaining quantity is burned once again under forced ventilation at the same temperature and the carbon black content determined by means of weight difference.

### Accessories



#### Simple and safe operation

- Complete test structure compactly assembled
- Overtemperature protection integrated in the tubular furnace

#### Reliable test results

- Precise temperature control via digital temperature controller

#### Lasting efficiency

- High-quality unit components guarantee a long service life

## ➤ Versions

		T041V1P
Furnace temperature range	°C	0 – 1000
Furnace accuracy		Up to 200 °C: 0.1 K Above 200 °C: 1 K
Carbon black tester accuracy		Up to 100 °C: 0.1% (±2 digits) Above 100 °C: 0.5 % (±2 digits)
Flow measuring device		5-95 NI/h or 1-13 NI/h
Power requirement of tubular furnace	kW	1
CE conformity		•
Permissible ambient temperature	°C	+5 to +30
Permissible relative humidity		Max. 70%, non-condensing
Width	mm	760
Depth	mm	650
Height	mm	1020
Weight	kg	Approx. 60

#### Voltage data

1 ph 230 V, 50/60 Hz (other voltages on request)

• included    ◦ available / optional    ◻ eligible    - not available



### Standards

ISO 6964

ASTM D 1603

# FALLING WEIGHT IMPACT TESTER



## Description

The falling weight tester is used to determine the external impact resistance of thermoplastic pipes using the staircase or round-the-clock method.

### Accessories



#### Simple and safe operation

- Convenient operation and clear visualisation via integrated touch display
- Two-hand operation when activating the test procedure to protect the operating personnel
- Test can only be carried out when the test chamber is closed

#### Reliable test results

- Precise weight positioning thanks to step motor

#### Lasting efficiency

- High-quality unit components guarantee high reliability, a long service life and low maintenance costs

#### State of the art technology

- State of the art PLC
- Automatic double impact prevention system.

## ➤ Versions

Max. drop height	m
Max. sample diameter	mm
Accuracy of height adjustment	mm
Drop weights	kg
Nose design	
Lowest drop height without double impact	m
Speed error margin (typical)	
Operation/visualisation	
CE conformity	
Permissible ambient temperature	°C
Permissible relative humidity	
Noise emission	
Width of tester	mm
Depth of tester	mm
Height of tester	mm
Width of control cabinet	mm
Depth of control cabinet	mm
Height of control cabinet	mm

### Voltage data

	T032630V1P	T032630V2P	T032630V3P
Max. drop height	2	2	2
Max. sample diameter	110	400	710
Accuracy of height adjustment		±10	
Drop weights		6.3 kg	
Nose design	Depending on the applicable standards		
Lowest drop height without double impact	Typically 0.5 (dependent on sample)		
Speed error margin (typical)	>5% of the theoretical falling speed		
Operation/visualisation	Touch display		
CE conformity	•		
Permissible ambient temperature	+5 to +30		
Permissible relative humidity	Max. 70%, non-condensing		
Noise emission	<70 dB(A) at rest (Noise generated on impact of the drop weight depending on the sample)		
Width of tester	980	980	980
Depth of tester	800	800	800
Height of tester	3000	3750	3750
Width of control cabinet		620	
Depth of control cabinet		460	
Height of control cabinet		1030	
Voltage data	3 ph 380/400 VAC 230/400 V, 50/60 Hz (other voltages on request)		

• included ○ available / optional □ eligible - not available



### Standards

ISO 11173

ISO 3127

ASTM D 2444

# RING STIFFNESS TESTER



## Description

The testing machines is designed to determine the ring stiffness, ring flexibility of thermo-plastic pipes. Both feature large compression plates which allow performing the test on the respective diameter range and on pipes with lengths of up to one meter. A PC based operational software enables clear representation of the machine and contributes to the usability. Different operational modes allow to either apply a constant compression to the sample or to continuously move the compression plates towards each other with constant speed. In both cases the applied or resulting forces and distances are recorded and the respective graphs are produced. Additionally the deflection of the outer or inner diameter of the pipe can be measured and recorded by a specific measuring system.

## Accessories



### Simple and safe operation

- Automatic processing of test scenario
- PC-based control software enables easy operation and a clearly represented visualization

### Reliable test results

- Especially designed to determine the ring stiffness, ring flexibility
- Continuous measuring and recording of the pipe's deformation on either outer or inner wall
- Continuous measuring and recording of compressive force

## ➤ Versions

Max. test force	kN	30
Max. outside diameter	mm	1000
Preload		Definable up to max. force
Accuracy		±1 % of measurement 0.40 up to 30 kN
Accuracy of measuring of deformation of the internal diameter		1 % of modification or 0.1 mm (max. value is valid)
Measuring range of distance measurement	mm	Min. 100 - max. 1000
Travel distance	mm	930
Extensometer		Integrated
PC based software		•
CE conformity		•
Permissible ambient temperature	°C	+5 to +30
Permissible relative humidity	mm	Max. 70%, non-condensing
Width	mm	1900
Depth	mm	1140
Height	mm	2030
Width Extensometer	mm	2200 (Extended)
Weight (incl. Extensometer)	t	ca. 1.75
<b>Voltage data</b>		<b>3 ph 380/400 VAC 230/400 V, 50/60 Hz (other voltages on request)</b>

• included    ◦ available / optional    □ eligible    - not available



## Standards

ISO 9967	DIN 16961
ISO 9969	ASTM D 2412
ISO 13968	

# THERMAL CYCLING TEST UNIT for PIPE SYSTEM



## Description

- High constancy of temperature by large reservoirs
- Static pressures up to 10 bar
- Accuracy pressure regulation
- Automatic failure detection
- Simultaneous testing of two separate pipe systems independently.
- Automatic test procedure with programmable numbers of cycles and cycle periods, temperatures, etc.
- Test chamber (optionally with fixing lates)
- Cold water tanks with chiller or heat exchanger, hot water tanks with heaters
- Flow measurement and regulation automated.
- Automatic calculation and application of prestress needed by the standardss via Stepper Motors

## Accessories

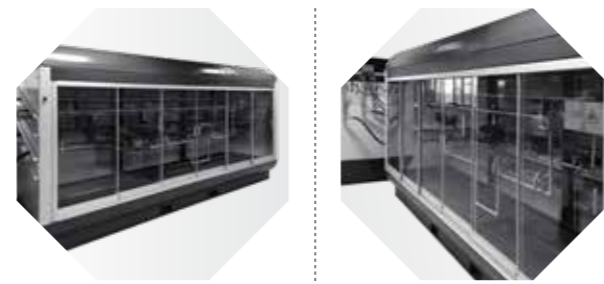

## Technical details

Pressure range	3 up to 10 bar, 15 to 95 °C
Test circuits capacity	up to 63 mm
Flow rate	Max. 1.0 l/sec
Max. test sample volume	12 l
Cycle period	Selectable between 1 and 9,999 min
Number of cycles	Max. 99,999 per test
Temperature range (hot)	Selectable between 50 and 95 °C
Temperature range (cold) with cooling unit	Selectable between 15 and 30 °C
Regulating accuracy	Temperature controller: approx. 0.5 °C In the tanks: approx. 1.0 °C
Permissible ambient temperature	5 - 25 °C
Max. relative humidity	70 %
Connection	
Power supply	230/400 V, 50 Hz; approx. 25 kW; constructed according to VDE 0100; protection class of switch box: IP 55
Water	G 3/4 inch external, min. 2 bar, max. 5 bar
Drain	HT pipe DN 2 x 40
Test sample	G 3/4 inch internal



## Standards

ISO 19893	DVGW W 542
ISO 10508	DVGW W 543
DVGW W 534	

# BENDING MACHINES for PLASTIC PIPES



## Description

- Pneumatic bending machine suitable for the construction of cross over special fittings by means of thermo-forming segments of Polypropylene Random (PP-R) pipe.

### Accessories

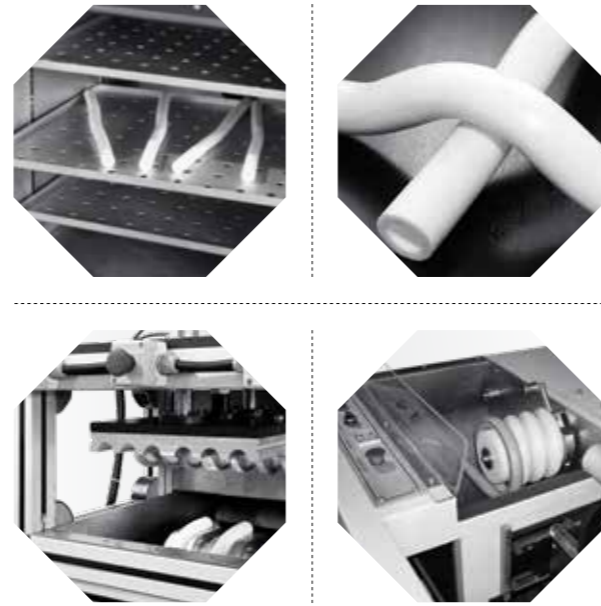

- A bench with pneumatic cutter for cutting segments of pipe to size with a box for collecting the pieces, and a heating unit able to prepare up to 8 pipe segments, ranging from Ø20 to 32 mm
- A station pressing bench with built in cooling unit. Supplied with - Bench complete with cutter, box for collecting the pieces, and heater;
- A station pressing bench with cooler and one mold for each diameter previewed from Ø 20 to Ø 32 mm.
- Press bending is the simplest and cheapest method of bending cold pipe and tube.
- The pipe or tube is restrained at two eternal points and a ram in the shape of the bend advances on the central axis and deforms the pipe.

## Versions

		T1201V1P BENDING MACHINE	T1101V2P OMEGA MACHINE
Working range	mm	20-40	20-30
Working pressure	Bar	6.0	6.0
CE conformity		•	•
Permissible ambient temperature	°C	+5 to +40	+5 to +40
Permissible relative humidity		Max.70	Max.70
Width (internal/external)	mm	800	1100
Depth (internal/external)	mm	700	800
Height (internal/external)	mm	1500	800
Voltage data		220/380V. 50/60 Hz	

● included ○ available / optional □ eligible - not available



### Standards

DIN EN ISO 15874  
DIN 8077  
DIN 8078

# BALL VALVES TEST UNITS for PLASTIC PIPES

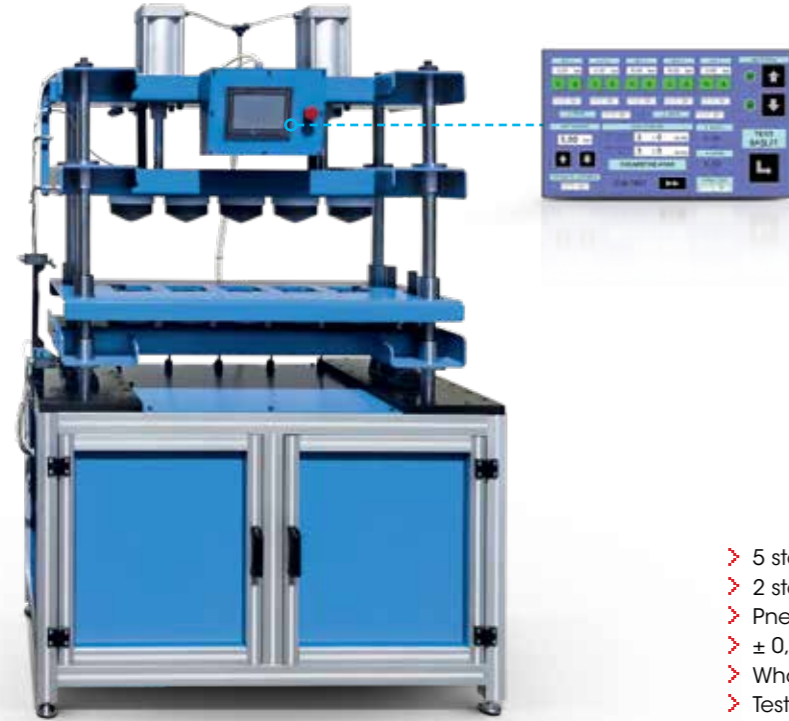

## Description

Statutory standards prescribe the verification of carbon black content of polyolefin plastics. The test method is based on pyrolytic decomposition of the material in an inert gas flow (nitrogen). This means that the remaining quantity is burned once again under forced ventilation at the same temperature and the carbon black content determined by means of weight difference.

## Accessories

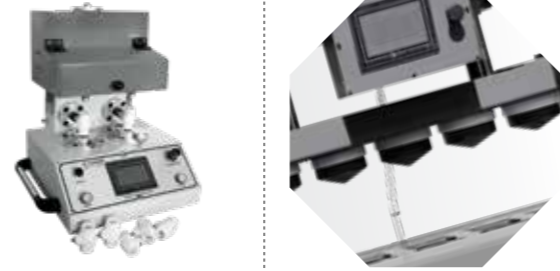

- > 5 stations can be active at a time between  $\varnothing 20 - \varnothing 63$  mm
- > 2 stations can be active at a time between  $\varnothing 75 - \varnothing 90$  mm
- > Pneumatic piston driven Head Closing
- >  $\pm 0.2$  bars testing pressure adjusting sensitivity between 0.5-6 bars.
- > Whole System PLC Control
- > Test Pressure and all other testing parameters can be defined, controlled and followed through Touchscreen User Interface.
- > Quick reachable prescriptions for the testing parameters with the help of Log-Memo function
- > Audio-Visual Warning and indication System
- > OPTIONAL: Quick Log Report System (PoliREPORT)
- > OPTIONAL: Windows based Data Collecting & Reporting System (PoliLOGGER)
- > Remote Operation & Test Control through PC (Start / Stop, Defining test parameters, following the test and reporting) (PoliCONTROL)

## Versions

	T1201V1P	T1101V2P
Working range	20-63	20-40
Test Bar	0.5-6.0	0.5-6.0
Test accuracy	$\pm 0.2$	$\pm 0.2$
CE conformity	•	•
Permissible ambient temperature	+5 to +40	+5 to +40
Permissible relative humidity	Max.70	Max.70
Width (internal/external)	1250	400
Depth (internal/external)	600	400
Height (internal/external)	2000	600

### Voltage data

220/380V. 50/60 Hz

• included    ◦ available / optional    ◻ eligible    - not available



## Standards

DIN EN ISO 15874  
EN 1329

# TEST OVEN for PIPE TESTING



## Description

The internal pressure creep test is a test procedure for determining the strength of thermoplastic pipes. The samples are subjected to a constant hydrostatic internal pressure at a constant ambient temperature either for a specified period or until they fail. The test duration is subject to the tension generated by the internal pressure and the temperature. The IPT test ovens are specially designed for testing thermoplastic pipes and fittings. The high reliability, long service life of the materials used and the constant temperatures in the test oven with respect to both volume and time provide particularly reliable test conditions. The efficient use of energy with low servicing and maintenance costs guarantees efficient longterm operation. There are a wide range of connection options, enabling the ovens to be flexibly adapted to various operating conditions.

## Accessories



### Easy and safe operation

- Sliding rack system enables the individual connections to be fitted more easily outside the oven
- Doors locked with safety switches and retrieval of the test pressure before doors are released

### Reliable test results

- Constant test temperatures thanks to highly-efficient water circulation and precise temperature control in the inner chamber

### Lasting efficiency

- High-quality stainless steel test oven (1.4571)
- High-quality oven insulation and insulated doors for minimum energy loss
- High-quality unit components guarantee high reliability, a long service life and low maintenance costs

### State of the art technology

- Extremely accurate temperature control in the entire inner chamber thanks to exceptionally high performance circulating air system
- Interface to Polinar®

## Versions

	T1101V1D TEST OVEN	T1101V2D ETUV OVEN	T1101V3D MUFFLE FUTNACE
Temperature range	5/150	5/250	1100
Regulating accuracy	±0.2	±0.2	±1
Temperature control	•	•	•
Inner chamber material	AISI 304	AISI 304	AISI 304
Power requirement of tubular furnace	1,5	3,5	3,0
CE conformity	•	•	•
Permissible ambient temperature	+5 to +40	+5 to +40	+5 to +40
Permissible relative humidity	Max.70	Max.70	Max.70
Width (internal/external)	800/900	550/850	170/370
Depth (internal/external)	600/700	500/700	220/520
Height (internal/external)	750/850	900/1100	170/550
Voltage data	220/380V. 50/60 Hz		

• included    ◦ available / optional    □ eligible    - not available



## Standards

ISO 1167  
ASTM D 1598  
ASTM D 1599

Quality and control  
for optimal production  
efficiency



Approach the  
Start position

Approach  
the Up

Approach  
the Down

Test Start

Emergency

---

# PLASTIC TEST **EQUIPMENT**

manufactured by POLINAR

---