

Polcomm® HFMill

F R E Z O W A N I E / M I L L I N G



Speed up with us!

Cztery efektywne rozwiązania Polcomm® HFMill do szybkich posuwów.

Four effective Polcomm® HFMill solutions for high-feed milling.



HFMill 150
AOMT 07



HFMill 209
BNUT 06



HFMill 140
SO..08



HFMill 141
SO..13



HFMill 150

AOMT 070208 MMZ

APMX
0,8 mm

max f_z
0,9 mm/t

wzmocniona krawędź tnąca z dodatnim kątem natarcia zapewnia płynne cięcie
reinforced cutting edge with positive rake face ensures smooth cutting



gatunek / grade	zastosowanie / application	obróbka / cutting
PC115	K S H	●
PC828	M S	●
PC228	P K	● ●

HFMill 209

BNUT 06T310 PMZ

APMX
1,0 mm

max f_z
1,5 mm/t

skręcona powierzchnia styku zwiększa niezawodność przy wysokich prędkościach posuwu
twisted contact surface increase reliability at high feed rates



PC228	P K	● ●
PC230	P K	⊕

BNUT 06T310 MMZ

APMX
1,0 mm

max f_z
1,4 mm/t

zwiększona wydajność dzięki ostrej krawędzi skrawającej oraz dodatniemu kątowi natarcia
sharp cutting edge and positive rake angle improved productivity



PC828	M	●
PC830	M S	●

HFMill 140

SOGW 080310 PMZ

APMX
1,0 mm

max f_z
2,2 mm/t

mocne krawędzie skrawające zwiększające wydajność w niestabilnych warunkach pracy
strong cutting edges increase efficiency in unstable working conditions



PC228	P K	●
PC230	P K	⊕

SOEX 080315 MMS

APMX
1,0 mm

max f_z
1,8 mm/t

ekstremalnie płynna obróbka dzięki innowacyjnej, wysoko pozytywnej geometrii
extremely smooth cutting by innovative high positive geometry



PC828	P M	●
PC830	M S	●

HFMill 141

SOGW 13M510 PMZ

APMX
1,5 mm

max f_z
2,2 mm/t

wyższa wytrzymałość i żywotność płytki dzięki zoptymalizowanej geometrii ostrzy
optimized edge geometry developed to improve insert mechanical resistance and lifetime



PC228	P K	●
PC230	P K	⊕

SOEX 13M520 MMS

APMX
1,5 mm

max f_z
1,8 mm/t

zoptymalizowana geometria zapewniająca większą stabilność i trwałość krawędzi
optimized geometry for greater stability and durability of the cutting edge



PC828	P M	●
PC830	M S	●

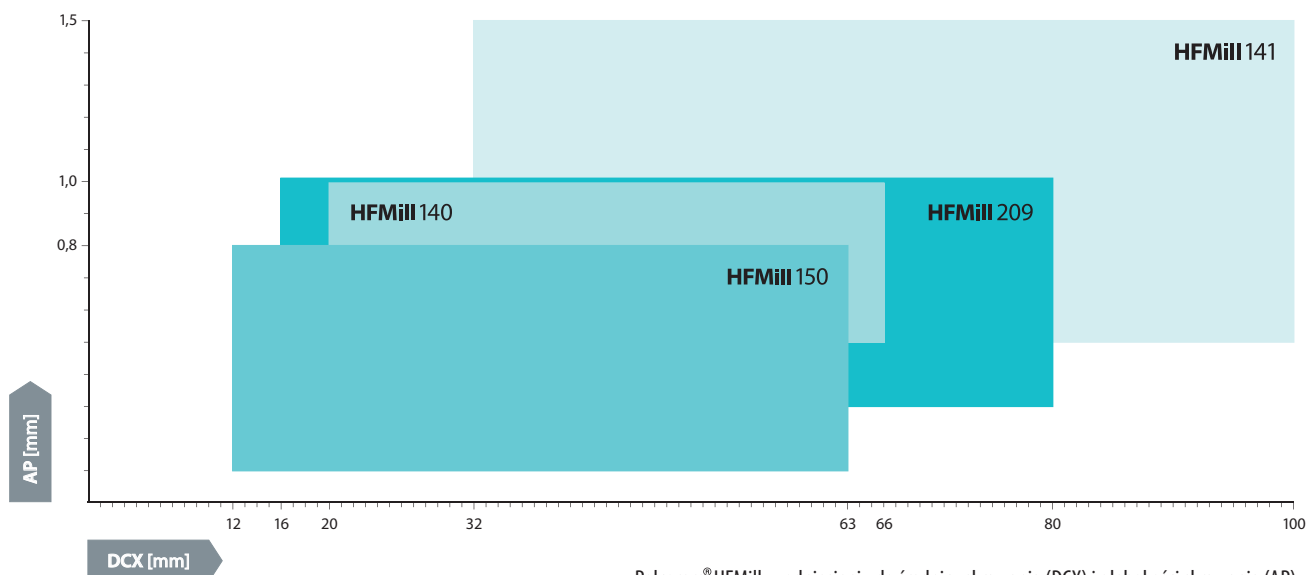

Polcomm® HFMill w odniesieniu do średnicy skrawania (DCX) i głębokości skrawania (AP)
Polcomm® HFMill Solutions in relation to cutting diameter (DCX) and depth of cut (AP)

wyjatkowe korzyści w zakresie wydajności exceptional performance advantages

- seria rozwiązań frezarskich zwiększająca produktywność
series of milling solutions to increase productivity
- unikalna konstrukcja płytek frezarskich do obróbki z dużymi posuwami
uniquely designed insert for high feed milling
- kilka geometrii i gatunków płytek obejmuje szeroki zakres zastosowań
several insert geometries and grades that covers a wide range of applications
- udoskonalone odprowadzanie wiórów
improved chip flow
- większa zdolność produkcyjna i obniżone koszty produkcji
higher manufacturing capacity and reduced costs of production

szeroki zakres zastosowań wide range of applications



frezowanie profilowe
profiling



frezowanie kieszeni
pocket milling



zagłębienie skośne liniowe
ramp milling



zagłębienie z interpolacją śrubową
helical interpolation



frezowanie czołowe
face milling



zagłębienie pionowe
plunging

Gatunki Polcomm® / Polcomm® grades

PC115

twardy gatunek pokryty cienką warstwą PVD; pierwszy wybór do frezowania twardych materiałów w stabilnych warunkach
hard grade coated with a thin PVD layer; first choice for milling hard materials under stable conditions

PC228

gatunek z powłoką PVD, który łączy lepszą odporność na zużycie z dużą twardością i odpornością na pękanie; pierwszy wybór do frezowania stali i żeliwa
PVD coated grade that combines an improved wear resistance with high hardness and cracking resistance; first choice for milling steel and cast iron

PC230

wytrzymały gatunek połączony z twardą powłoką PVD, opracowaną do frezowania stali i żeliwa w trudnych warunkach
a tough grade merged with a hard PVD coating developed for milling steel and cast iron in difficult conditions

PC828

gatunek powlekany cienką warstwą PVD o wysokiej gęstości i odporności termicznej; doskonały wybór do frezowania stali nierdzewnej w stabilnych warunkach
grade coated with a thin PVD layer with high density and high thermal resistance; excellent choice for milling stainless steel under stable conditions

PC830

gatunek z cienkowarstwową powłoką PVD o wysokiej odporności na ścieranie, opracowany specjalnie do pracy w wysokich temperaturach; pierwszy wybór do frezowania stali nierdzewnej i stopów żaroodpornych
thin layer PVD coated grade with high wear resistance specially developed to work under high temperatures; first choice for milling stainless steel and heat-resistant alloys



HFMiII 150

GN150

głowice nasadzone / arbor type cutters

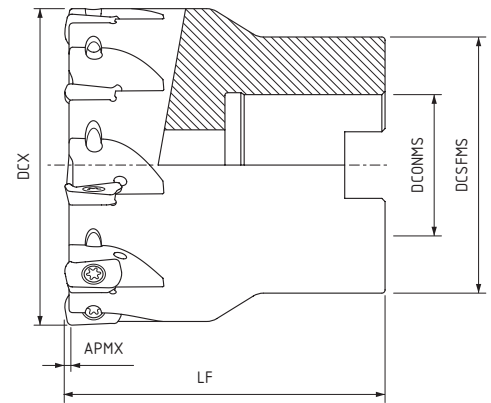
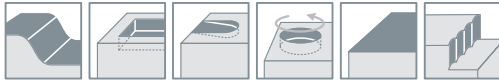

ID Polcomm® Polcomm® ordering number	DCX [mm]	DCONMS [mm]	DCSFMS [mm]	LF [mm]	ZEFP	APMX [mm]	typ mocowania arbor type	chłodzenie cooling	WT [kg]	plytka insert	dostępność stock
GN150 040A16 04007I	40	16	30	40	7	0,8	A	●	0,21	AOMT 0702..	●
GN150 050A22 05009I	50	22	40	50	9	0,8	A	●	0,45	AOMT 0702..	●
GN150 063A22 05012I	63	22	48	50	12	0,8	A	●	0,76	AOMT 0702..	●

GW150

głowice wkręcane / screw type cutters

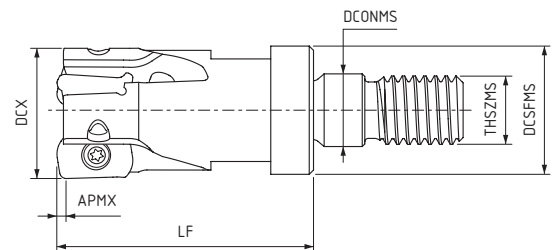

ID Polcomm® Polcomm® ordering number	DCX [mm]	DCONMS [mm]	DCSFMS [mm]	LF [mm]	THSZMS	ZEFP	APMX [mm]	chłodzenie cooling	WT [kg]	plytka insert	dostępność stock
GW150 012M06 02502I	12	6,5	9,8	25	M06	2	0,8	●	0,01	AOMT 0702..	○
GW150 016M08 03003I	16	8,5	13	30	M08	3	0,8	●	0,03	AOMT 0702..	○
GW150 020M10 03004I	20	10,5	16	30	M10	4	0,8	●	0,05	AOMT 0702..	○
GW150 025M12 03505I	25	12,5	21	35	M12	5	0,8	●	0,10	AOMT 0702..	○
GW150 032M16 03506I	32	17,0	29	35	M16	6	0,8	●	0,15	AOMT 0702..	○

● dostępne / on stock ○ na zamówienie / available on request



głowice trzpieniowe / shank type cutters

GT150

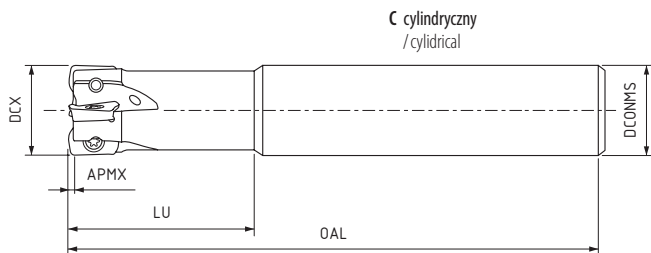

ID Polcomm® Polcomm® ordering number	DCX [mm]	DCONMS [mm]	OAL [mm]	LU [mm]	ZEFP	APMX [mm]	typ chwytu shank type	chłodzenie cooling	WT [kg]	plytka insert	dostępność stock
GT150 012C12 10002I	12	12	100	39	2	0,8	C	●	0,08	AOMT 0702..	●
GT150 125C12 12602I	12,5	12	126	30	2	0,8	C	●	0,10	AOMT 0702..	●
GT150 016C16 08404I	16	16	84	24	4	0,8	C	●	0,11	AOMT 0702..	●
GT150 016C16 14502I	16	16	145	64	2	0,8	C	●	0,19	AOMT 0702..	●
GT150 020C20 10005I	20	20	100	39	5	0,8	C	●	0,20	AOMT 0702..	●
GT150 020C20 18503I	20	20	185	84	3	0,8	C	●	0,38	AOMT 0702..	●
GT150 025C25 13507I	25	25	135	58	7	0,8	C	●	0,44	AOMT 0702..	●
GT150 025C25 22003I	25	25	220	98	3	0,8	C	●	0,72	AOMT 0702..	●
GT150 032C32 12508I	32	32	125	65	8	0,8	C	●	0,71	AOMT 0702..	●
GT150 032C32 23004I	32	32	230	129	4	0,8	C	●	1,30	AOMT 0702..	●

● dostępne / on stock ○ na zamówienie / available on request

Części zamienne / Spare parts

zakres średnic diameter range	śruba screw	klucz wrench	zalecany moment dokręcenia recommended torque
G. 150 012... - G. 150 063...	N01-003092	N01-003199	1,0 Nm



AOMT07

plytki frezarskie / milling inserts

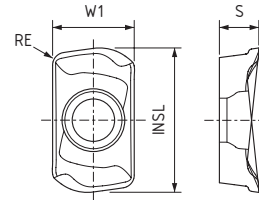

MMZ

AOMT 070208 MMZ

P		● ●		
M			●	
K	●	●		
N				
S	●		●	
H	●			

- obróbka stabilna / stable cutting
- obróbka ogólna / general cutting
- ✚ obróbka niestabilna / unstable cutting

oznaczenie designation	PC115 ID Polcomm® (ordering number)	PC228	PC828	W1 [mm]	S [mm]	INSL [mm]	RE [mm]	APMX [mm]
AOMT 070208 MMZ	92207 ●	32006 ●	31905 ●	4,9	2,4	8,8	0,8	0,8

● dostępne / on stock ○ na zamówienie / available on request



parametry techniczne / technical parameters



Zalecane parametry skrawania / Recommended cutting conditions

ISO	obrabiany materiał work material	twardość hardness	gatunek Polcomm® Polcomm® grade	Vc [mm/min]	geometria geometry	fz [mm/t]
P	stale niestopowe non-alloy steel	125-220 HB	PC228	90-200	MMZ	0,4-0,9
	stale niskostopowe low-alloy steel	220-280 HB	PC228	90-150	MMZ	0,4-0,9
	stale wysokostopowe high-alloy steel	280-380 HB	PC228	80-180	MMZ	0,4-0,9
M	stale nierdzewne martenzytyczne i ferrytyczne martensitic and ferritic stainless steel	200-330 HB	PC828	90-150	MMZ	0,4-0,9
	stale nierdzewne austenityczne austenitic stainless steel	200-330 HB	PC828	90-150	MMZ	0,4-0,9
	stale nierdzewne austenityczno-ferrytyczne stainless steel austenitic-ferritic (duplex)	230-260 HB	PC828	90-150	MMZ	0,4-0,9
K	żeliwa szare grey cast iron	130-230 HB	PC115	110-250	MMZ	0,4-0,9
			PC228	100-180	MMZ	0,4-0,9
	żeliwa sferoidalne nodular cast iron	160-250 HB	PC115	100-240	MMZ	0,4-0,9
			PC228	80-150	MMZ	0,4-0,9
S	stopy żaroodporne heat-resistant alloys	200-320 HB	PC115	30-60	MMZ	0,2-0,9
			PC828	20-50	MMZ	0,2-0,9
H	stale hartowane hardened steel	40-55 HRC	PC115	20-100	MMZ	0,2-0,9

Uwagi: / Notes:

Powyższe parametry skrawania podano w celach informacyjnych. / Cutting conditions are just for reference.

Warunki skrawania są ograniczone przez sztywność przedmiotu obrabianego, moc maszyny i wysięg narzędzia. Gdy szerokość skrawania, głębokość lub długość wysięgu jest duża, należy ustawić Vc i fz na minimalną zalecaną wartość i sprawdzić wibracje oraz moc maszyny. / Cutting conditions are limited by workpiece rigidity, machine power and tool overhang. When the cutting width, depth or overhang length is large, set Vc and fz to the minimum recommended value and check vibrations and machine power.

W przypadku frezowania ze zmienną głębokością skrawania (na przykład na powierzchni odlewu) lub na nierównych powierzchniach, wartość posuwu (fz) należy zredukować do niższej zalecanej wartości podanej w tabeli powyżej. / When operation occurs with variable depth of cut (for example over casting skin) or over interrupted surfaces, feed value (fz) should be reduced to the lower recommended value shown in the table above.

Aby zapobiec zakleszczaniu się wiórow, ich nadmiar z obszaru roboczego należy usuwać strumieniem powietrza. / Excess of chips should be removed from working area with air blast to prevent chip jamming.



Geometria narzędzi do celów programowania / Programming data

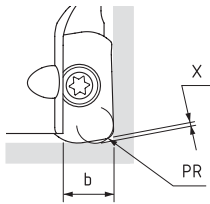

plytka / insert	PR [mm]	X [mm]	b [mm]
AOMT 0702..	1,0	0,3	3,0

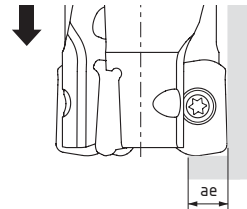

zagłębienie pionowe / plunging

plytka / insert	max ae [mm]
AOMT 0702..	2,7

Zagłębienie skośne i interpolacja śrubowa / Ramping & helical milling

zagłębienie skośne ramping			interpolacja śrubowa (otwór nieprzelotowy z płaskim dnem) helical interpolation (blind hole, flat bottom)			
DCX [mm]	RMPX [°]	L [mm]*	DH max [mm]	P max [mm]	DH min [mm]	P max [mm]
12	5,0	9,1	22,4	0,8	18	0,8
12,5	5,0	9,1	23,4	0,8	19	0,8
16	3,0	15,3	30,4	0,8	26	0,8
20	2,1	21,8	38,4	0,8	34	0,8
25	1,6	28,6	48,4	0,8	44	0,8
32	1,1	41,7	62,4	0,8	58	0,8
40	0,8	57,3	78,4	0,8	74	0,8
50	0,5	91,7	98,4	0,8	94	0,8
63	0,3	152,8	124,4	0,8	120	0,8

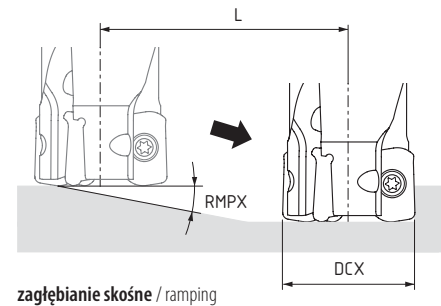

zagłębienie skośne / ramping

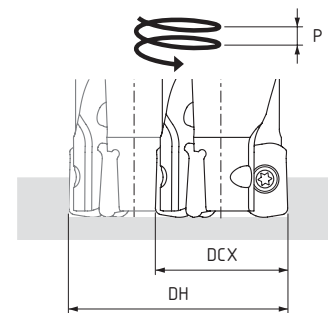

interpolacja śrubowa / helical interpolation

Stosowany kąt zagłębienia skośnego powinien być poniżej RMPX / Ramping angle used should be under RMPX.

Szybkość posuwu powinna być mniejsza niż 70% wskazanych wartości / Feed rate should be under 70% of indicated values.

* Minimalny dystans frezowania przy maksymalnym kącie pochylecia do momentu, gdy głębokość skrawania osiągnie APMX (0,8 mm) / Minimum distance made by cutter until depth of cut reaches APMX (0,8 mm) at maximum ramping angle.

Zagłębienie pionowe / Plunging

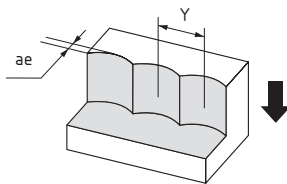

OAL ≤ 3DCX fz [mm/t]	OAL > 3DCX fz [mm/t]	Y max
0,08-0,15	0,05-0,10	$Y_{max} = \sqrt{DCX \times ae - ae^2}$

Y max i ae w zależności od średnicy skrawania DCX / Y max and ae corresponding cutting diameter DCX

DCX [mm]	12	12,5	16	20	25	32	40	50	63
ae [mm]	Y max [mm]								
1	3,3	3,4	3,9	4,4	4,9	5,6	6,2	7,0	7,9
2	4,5	4,6	5,3	6,0	6,8	7,7	8,7	9,8	11,0
3	5,2	5,3	6,2	7,1	8,1	9,3	10,5	11,9	13,4

Uwaga: dla bardzo długich narzędzi, gdy OAL ≥ 4DCX, zalecane jest zredukowanie wartości Y i ae.
Note: for very long tools, when OAL ≥ 4DCX, it is recommended to reduce the Y and ae values.



HFMill 209



głowice nasadzone / arbor type cutters

GN209

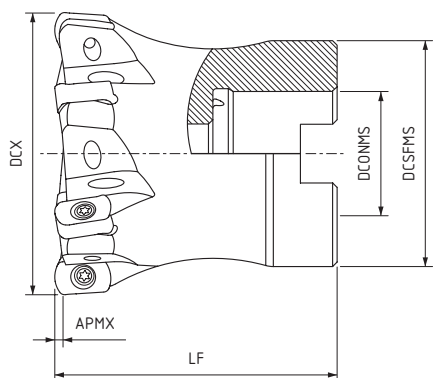

ID Polcomm® Polcomm® ordering number	DCX [mm]	DCONMS [mm]	DCSFMS [mm]	LF [mm]	ZEFP	APMX [mm]	typ mocowania arbor type	chłodzenie cooling	WT [kg]	plytka insert	dostępność stock
GN209 040A16 04006I	40	16	36	40	6	1,0	A	●	0,24	BNUT 06T3..	●
GN209 050A22 05006I	50	22	40	50	6	1,0	A	●	0,37	BNUT 06T3..	●
GN209 052A22 05008I	52	22	40	50	8	1,0	A	●	0,39	BNUT 06T3..	●
GN209 063A27 05008I	63	27	48	50	8	1,0	A	●	0,56	BNUT 06T3..	●
GN209 066A27 05009I	66	27	48	50	9	1,0	A	●	0,61	BNUT 06T3..	●
GN209 080A27 05010I	80	27	60	50	10	1,0	A	●	0,96	BNUT 06T3..	●



głowice wkręcane / screw type cutters

GW209

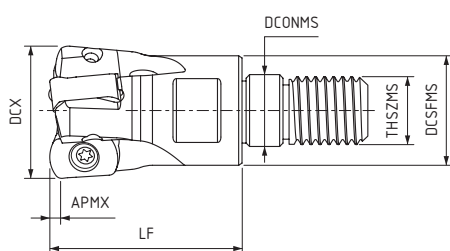

ID Polcomm® Polcomm® ordering number	DCX [mm]	DCONMS [mm]	DCSFMS [mm]	LF [mm]	THSZMS	ZEFP	APMX [mm]	chłodzenie cooling	WT [kg]	plytka insert	dostępność stock
GW209 016M08 02502I	16	8,5	13	25	M08	2	1,0	●	0,05	BNUT 06T3..	●
GW209 020M10 02803I	20	10,5	16	28	M10	3	1,0	●	0,07	BNUT 06T3..	●
GW209 025M12 03004I	25	12,5	21	30	M12	4	1,0	●	0,11	BNUT 06T3..	●
GW209 032M16 03505I	32	17	29	35	M16	5	1,0	●	0,21	BNUT 06T3..	●
GW209 035M16 03506I	35	17	29	35	M16	6	1,0	●	0,22	BNUT 06T3..	●
GW209 040M16 04506I	40	17	29	45	M16	6	1,0	●	0,30	BNUT 06T3..	●
GW209 042M16 04507I	42	17	29	45	M16	7	1,0	●	0,31	BNUT 06T3..	●

● dostępne / on stock ○ na zamówienie / available on request



GT209

głowice trzpieniowe / shank type cutters

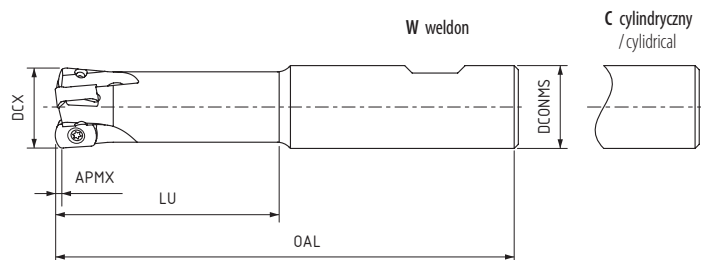

ID Polcomm® Polcomm® ordering number	DCX [mm]	DCONMS [mm]	OAL [mm]	LU [mm]	ZEFP	APMX [mm]	typ chwytu shank type	chłodzenie cooling	WT [kg]	plytka insert	dostępność stock
GT209 016W16 15002I	16	16	150	50	2	1,0	W	●	0,22	BNUT 06T3..	●
GT209 018W16 16002I	18	16	160	90	2	1,0	W	●	0,24	BNUT 06T3..	●
GT209 020W20 16003I	20	20	160	90	3	1,0	W	●	0,33	BNUT 06T3..	●
GT209 025W25 18004I	25	25	180	100	4	1,0	W	●	0,59	BNUT 06T3..	●
GT209 032W32 20005I	32	32	200	120	5	1,0	W	●	1,07	BNUT 06T3..	●
GT209 016C15 15002I	16	15	150	40	2	1,0	C	●	0,21	BNUT 06T3..	●
GT209 016C16 10002I	16	16	100	30	2	1,0	C	●	0,16	BNUT 06T3..	●
GT209 016C16 15002I	16	16	150	40	2	1,0	C	●	0,23	BNUT 06T3..	●
GT209 020C19 18003I	20	19	180	80	3	1,0	C	●	0,35	BNUT 06T3..	●
GT209 020C20 13003I	20	20	130	50	3	1,0	C	●	0,28	BNUT 06T3..	●
GT209 020C20 20003I	20	20	200	80	3	1,0	C	●	0,44	BNUT 06T3..	●
GT209 025C25 14004I	25	25	140	60	4	1,0	C	●	0,48	BNUT 06T3..	●
GT209 025C24 18004I	25	24	180	100	4	1,0	C	●	0,59	BNUT 06T3..	●
GT209 025C25 22004I	25	25	220	70	4	1,0	C	●	0,77	BNUT 06T3..	●
GT209 032C32 15005I	32	32	150	70	5	1,0	C	●	0,83	BNUT 06T3..	●
GT209 032C32 20005I	32	32	200	120	5	1,0	C	●	1,08	BNUT 06T3..	●

● dostępne / on stock ○ na zamówienie / available on request

Części zamienne / Spare parts

zakres średnic diameter range	śruba screw	klucz wrench	zalecany moment dokręcenia recommended torque
G. 209 016... - G. 209 080...	N01-003118	N01-003213	1,0 Nm



plytki frezarskie / milling inserts

BNUT06



BNUT 06T310 PMZ

BNUT 06T310 MMZ

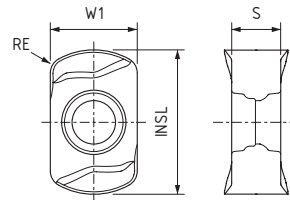

PMZ/MMZ

P	● ●	⚡			
M			●	●	
K	● ●	⚡			
N					
S				●	
H					

- obróbka stabilna / stable cutting
- obróbka ogólna / general cutting
- ⚡ obróbka niestabilna / unstable cutting

oznaczenie designation	PC228	PC230	PC828	PC830	W1 [mm]	S [mm]	INSL [mm]	RE [mm]	APMX [mm]
BNUT 06T310 PMZ	53471 ●	26022 ●			6	3,4	10	1,1	1,0
BNUT 06T310 MMZ			69779 ●	89813 ●	6	3,4	10	1,1	1,0

● dostępne / on stock ○ na zamówienie / available on request



parametry techniczne / technical parameters

Zalecane parametry skrawania / Recommended cutting conditions

ISO	obrabiany materiał work material	twardość hardness	gatunek Polcomm® Polcomm® grade	Vc [mm/min]	geometria geometry	fz [mm/t]
P	stale niestopowe non-alloy steel	125-220 HB	PC228	180-250	PMZ	0,5-1,5
			PC230	160-230	PMZ	0,5-1,5
	stale niskostopowe low-alloy steel	220-280 HB	PC228	160-240	PMZ	0,5-1,5
			PC230	150-190	PMZ	0,5-1,5
	stale wysokostopowe high-alloy steel	280-380 HB	PC228	140-230	PMZ	0,5-1,5
			PC230	140-180	PMZ	0,5-1,5
M	stale nierdzewne martenzytyczne i ferrytyczne martensitic and ferritic stainless steel	200-330 HB	PC828	140-200	MMZ	0,5-1,4
			PC830	130-170	MMZ	0,5-1,4
	stale nierdzewne austenityczne austenitic stainless steel	200-330 HB	PC828	120-180	MMZ	0,5-1,4
			PC830	100-160	MMZ	0,5-1,4
	stale nierdzewne austenityczno-ferrytyczne stainless steel austenitic-ferritic (duplex)	230-260 HB	PC828	90-120	MMZ	0,5-1,4
			PC830	80-140	MMZ	0,5-1,4
K	żeliwa szare grey cast iron	130-230 HB	PC228	160-300	PMZ	0,5-1,5
			PC230	150-300	PMZ	0,5-1,5
	żeliwa sferoidalne nodular cast iron	160-250 HB	PC228	150-210	PMZ	0,5-1,5
			PC230	80-220	PMZ	0,5-1,5
S	stopy żaroodporne heat-resistant alloys	200-320 HB	PC830	30-75	MMZ	0,5-1,3

Uwagi: / Notes:

Powyższe parametry skrawania podano w celach informacyjnych. / Cutting conditions are just for reference.

Warunki skrawania są ograniczone przez sztywność przedmiotu obrabianego, moc maszyny i wysięg narzędzia. Gdy szerokość skrawania, głębokość lub długość wysięgu jest duża, należy ustawić Vc i fz na minimalną zalecaną wartość i sprawdzić wibracje oraz moc maszyny. / Cutting conditions are limited by workpiece rigidity, machine power and tool overhang. When the cutting width, depth or overhang length is large, set Vc and fz to the minimum recommended value and check vibrations and machine power.

W przypadku frezowania ze zmienną głębokością skrawania (na przykład na powierzchni odlewu) lub na nierównych powierzchniach, wartość posuwu (fz) należy zredukować do niższej zalecanej wartości podanej w tabeli powyżej. / When operation occurs with variable depth of cut (for example over casting skin) or over interrupted surfaces, feed value (fz) should be reduced to the lower recommended value shown in the table above.

Aby zapobiec zakleszczaniu się wiórów, ich nadmiar z obszaru roboczego należy usuwać strumieniem powietrza. / Excess of chips should be removed from working area with air blast to prevent chip jamming.



Geometria narzędzi do celów programowania / Programming data

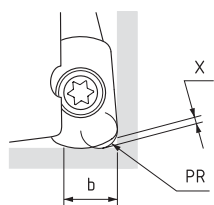

plytka / insert	PR [mm]	X [mm]	b [mm]
BNUT 06T3..	1,8	0,3	3,8

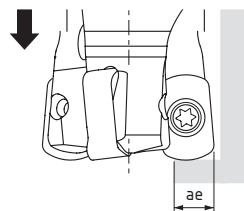

zagłębienie pionowe / plunging

plytka / insert	max ae [mm]
BNUT 06T3..	3,6

Zagłębienie skośne i interpolacja śrubowa / Ramping & helical milling

zagłębienie skośne ramping			interpolacja śrubowa (otwór nieprzelotowy z płaskim dnem) helical interpolation (blind hole, flat bottom)			
DCX [mm]	RMPX [°]	L [mm]*	DH max [mm]	P max [mm]	DH min [mm]	P max [mm]
16	0,5	114,6	30	0,38	24	0,23
18	0,5	114,6	34	0,43	28	0,28
20	0,5	114,6	38	0,49	32	0,33
25	0,8	71,6	48	1,00	42	0,76
32	0,8	71,6	62	1,00	56	1,00
35	0,5	114,6	68	0,90	62	0,75
40	0,4	143,2	78	1,00	72	0,88
42	0,4	143,2	82	0,87	76	0,75
50	0,2	286,5	98	0,52	92	0,46
52	0,2	286,5	102	0,54	96	0,48
63	0,2	286,5	124	0,66	118	0,60
66	0,2	286,5	130	0,70	124	0,64
80	0,1	573,0	158	0,42	152	0,39

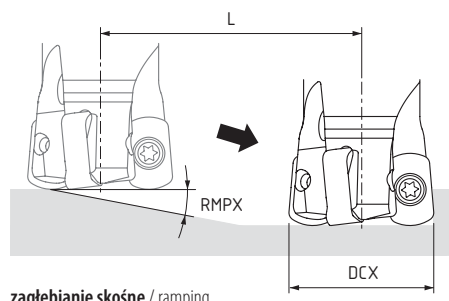

zagłębienie skośne / ramping

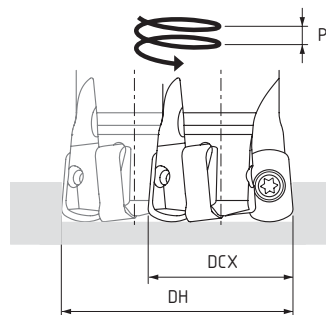

interpolacja śrubowa / helical interpolation

Stosowany kąt zagłębienia skośnego powinien być poniżej RMPX / Ramping angle used should be under RMPX.
 Szybkość posuwu powinna być mniejsza niż 70% wskazanych wartości / Feed rate should be under 70% of indicated values.
 * Minimalny dystans frezowania przy maksymalnym kącie pochylenia do momentu, gdy głębokość skrawania osiągnie APMX (1,0 mm) / Minimum distance made by cutter until depth of cut reaches APMX (1,0 mm) at maximum ramping angle.

Zagłębienie pionowe / Plunging

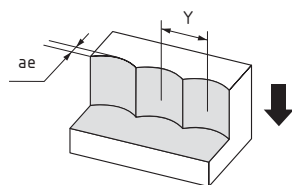

OAL ≤ 3DCX fz [mm/t]	OAL > 3DCX fz [mm/t]	Y max
0,08-0,15	0,05-0,10	$Y_{max} = \sqrt{DCX \times ae - ae^2}$

Y max i ae w zależności od średnicy skrawania DCX / Y max and ae corresponding cutting diameter DCX

DCX [mm]	16	18	20	25	32	35	40	42	50	52	63	66	80
ae [mm]	Y max [mm]												
1	3,9	4,1	4,4	4,9	5,6	5,8	6,2	6,4	7,0	7,1	7,9	8,1	8,9
2	5,3	5,7	6,0	6,8	7,7	8,1	8,7	8,9	9,8	10,0	11,0	11,3	12,5
3	6,2	6,7	7,1	8,1	9,3	9,8	10,5	10,8	11,9	12,1	13,4	13,7	15,2

Uwaga: dla bardzo długich narzędzi, gdy OAL ≥ 4DCX, zalecane jest zredukowanie wartości Y i ae.
 Note: for very long tools, when OAL ≥ 4DCX, it is recommended to reduce the Y and ae values.



HFMill 140

GN140

głowice nasadzone / arbor type cutters

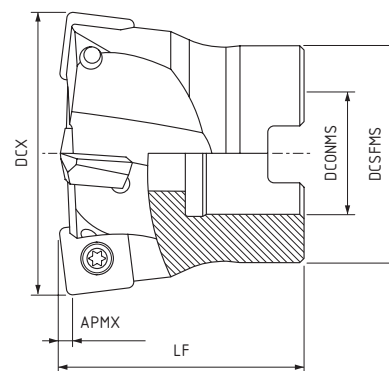

ID Polcomm® Polcomm® ordering number	DCX [mm]	DCONMS [mm]	DCSFMS [mm]	LF [mm]	ZEFP	APMX [mm]	typ mocowania arbor type	chłodzenie cooling	WT [kg]	plytka insert	dostępność stock
GN140 040A16 04005I	40	16	36	40	5	1,0	A	●	0,15	SO.. 0803..	●
GN140 040A16 04006I	40	16	36	40	6	1,0	A	●	0,13	SO.. 0803..	●
GN140 050A22 04506I	50	22	40	45	6	1,0	A	●	0,30	SO.. 0803..	●
GN140 050A22 04507I	50	22	40	45	7	1,0	A	●	0,28	SO.. 0803..	●
GN140 052A22 04506I	52	22	40	45	6	1,0	A	●	0,35	SO.. 0803..	●
GN140 052A22 04507I	52	22	40	45	7	1,0	A	●	0,32	SO.. 0803..	●
GN140 066A27 05007I	66	27	48	50	7	1,0	A	●	0,55	SO.. 0803..	●
GN140 066A27 05008I	66	27	48	50	8	1,0	A	●	0,52	SO.. 0803..	●

GW140

głowice wkręcane / screw type cutters

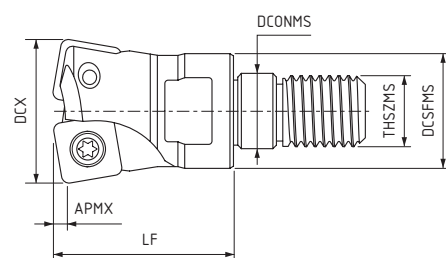

ID Polcomm® Polcomm® ordering number	DCX [mm]	DCONMS [mm]	DCSFMS [mm]	LF [mm]	THSZMS	ZEFP	APMX [mm]	chłodzenie cooling	WT [kg]	plytka insert	dostępność stock
GW140 020M10 02502I	20	10,5	16	25	M10	2	1,0	●	0,04	SO.. 0803..	●
GW140 025M12 02803I	25	12,5	21	28	M12	3	1,0	●	0,06	SO.. 0803..	●
GW140 032M16 03504I	32	17	29	35	M16	4	1,0	●	0,15	SO.. 0803..	●
GW140 035M16 03504I	35	17	29	35	M16	4	1,0	●	0,18	SO.. 0803..	●
GW140 042M16 03505I	42	17	29	35	M16	5	1,0	●	0,22	SO.. 0803..	●

● dostępne / on stock ○ na zamówienie / available on request



głowice trzpieniowe / shank type cutters

GT140

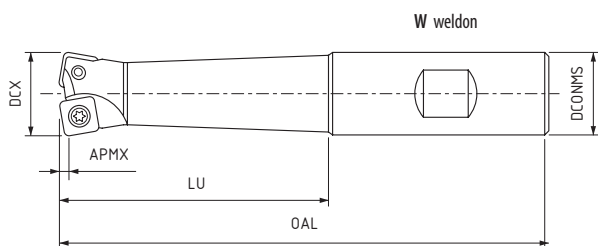

ID Polcomm® Polcomm® ordering number	DCX [mm]	DCONMS [mm]	OAL [mm]	LU [mm]	ZEPF	APMX [mm]	typ chwytu shank type	chłodzenie cooling	WT [kg]	plytka insert	dostępność stock
GT140 020W20 13002I	20	20	130	75	2	1,0	W	●	0,35	SO.. 0803..	●
GT140 020W20 19002I	20	20	190	110	2	1,0	W	●	0,34	SO.. 0803..	●
GT140 025W25 14003I	25	25	140	80	3	1,0	W	●	0,40	SO.. 0803..	●
GT140 025W25 20003I	25	25	200	130	3	1,0	W	●	0,55	SO.. 0803..	●
GT140 032W32 15004I	32	32	150	90	4	1,0	W	●	0,75	SO.. 0803..	●
GT140 032W32 20004I	32	32	200	130	4	1,0	W	●	1,00	SO.. 0803..	●

● dostępne / on stock ○ na zamówienie / available on request

Części zamienne / Spare parts

zakres średnic diameter range	śruba screw	klucz wrench	zalecany moment dokręcenia recommended torque
G. 140 020... - G. 140 066...	N01-004743	N01-003201	2,5 Nm



SO..08

plytki frezarskie / milling inserts



SOGW 080310 PMZ



SOEX 080315 MMS

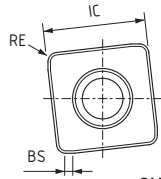

PMZ

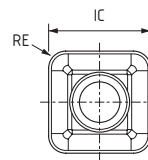
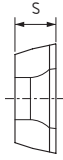

MMS



P	●	⚡	●	
M			●	●
K	●	⚡		
N				
S				●
H				

- obróbka stabilna / stable cutting
- obróbka ogólna / general cutting
- ⚡ obróbka niestabilna / unstable cutting

oznaczenie designation	PC228	PC230	PC828	PC830	IC [mm]	S [mm]	BS [mm]	RE [mm]	APMX [mm]
SOGW 080310 PMZ	87676 ●	64139 ●			8,6	3,47	1,0	1,0	1,0
SOEX 080315 MMS			87102 ●	94919 ●	8,6	3,47	-	1,5	1,0

● dostępne / on stock ○ na zamówienie / available on request



parametry techniczne / technical parameters



Zalecane parametry skrawania / Recommended cutting conditions

ISO	obrabiany materiał work material	twardość hardness	gatunek Polcomm® Polcomm® grade	Vc [mm/min]	geometria geometry	fz [mm/t]
P	stale niestopowe non-alloy steel	125-220 HB	PC228	180-250	PMZ	0,4-1,8
			PC230	160-230	PMZ	0,4-1,8
			PC828	180-250	MMS	0,4-1,8
	stale niskostopowe low-alloy steel	220-280 HB	PC228	160-240	PMZ	0,4-1,8
			PC230	150-190	PMZ	0,4-1,8
			PC828	160-240	MMS	0,4-1,8
	stale wysokostopowe high-alloy steel	280-380 HB	PC228	140-220	PMZ	0,5-1,5
			PC230	140-180	PMZ	0,5-1,5
			PC828	140-220	MMS	0,4-1,8
M	stale nierdzewne martenzytyczne i ferrytyczne martensitic and ferritic stainless steel	200-330 HB	PC828	160-220	MMS	0,4-1,3
			PC830	140-210	MMS	0,4-1,3
	stale nierdzewne austenityczne austenitic stainless steel	200-330 HB	PC828	140-190	MMS	0,4-1,3
			PC830	120-170	MMS	0,4-1,3
	stale nierdzewne austenityczno-ferrytyczne stainless steel austenitic-ferritic (duplex)	230-260 HB	PC828	120-170	MMS	0,1-1,0
			PC830	100-150	MMS	0,1-1,0
K	żeliwa szare grey cast iron	130-230 HB	PC228	140-270	PMZ	0,5-2,2
			PC230	120-250	PMZ	0,5-2,2
	żeliwa sferoidalne nodular cast iron	160-250 HB	PC228	120-210	PMZ	0,5-2,2
			PC230	100-190	PMZ	0,5-2,2
S	stopy żaroodporne heat-resistant alloys	200-320 HB	PC830	30-110	MMS	0,4-1,3

Uwagi: / Notes:

Powyższe parametry skrawania podano w celach informacyjnych. / Cutting conditions are just for reference.

Warunki skrawania są ograniczone przez sztywność przedmiotu obrabianego, moc maszyny i wysięg narzędzia. Gdy szerokość skrawania, głębokość lub długość wysięgu jest duża, należy ustawić Vc i fz na minimalną zalecaną wartość i sprawdzić wibracje oraz moc maszyny. / Cutting conditions are limited by workpiece rigidity, machine power and tool overhang. When the cutting width, depth or overhang length is large, set Vc and fz to the minimum recommended value and check vibrations and machine power.

W przypadku frezowania ze zmienną głębokością skrawania (na przykład na powierzchni odlewu) lub na nierównych powierzchniach, wartość posuwu (fz) należy zredukować do niższej zalecanej wartości podanej w tabeli powyżej. / When operation occurs with variable depth of cut (for example over casting skin) or over interrupted surfaces, feed value (fz) should be reduced to the lower recommended value shown in the table above.

Aby zapobiec zakleszczaniu się wiórów, ich nadmiar z obszaru roboczego należy usuwać strumieniem powietrza. / Excess of chips should be removed from working area with air blast to prevent chip jamming.



Geometria narzędzi do celów programowania / Programming data

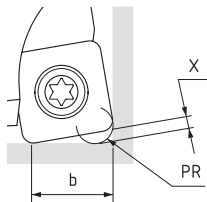

plytka / insert	PR [mm]	X [mm]	b [mm]
S0.. 0803..	2,0	0,8	6,8

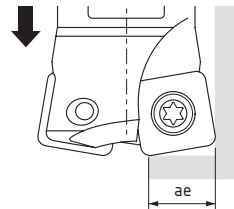

zagłębienie pionowe / plunging

plytka / insert	max ae [mm]
S0.. 0803..	6,3

Zagłębienie skośne i interpolacja śrubowa / Ramping & helical milling

zagłębienie skośne ramping			interpolacja śrubowa (otwór nieprzelotowy z płaskim dnem) helical interpolation (blind hole, flat bottom)			
DCX [mm]	RMPX [°]	L [mm]*	DH max [mm]	P max [mm]	DH min [mm]	P max [mm]
20	15,0	3,7	38	1,0	26	1,0
25	9,5	6,0	48	1,0	36	1,0
32	5,5	10,4	62	1,0	50	1,0
35	4,5	12,7	68	1,0	56	1,0
40	3,5	16,3	78	1,0	66	1,0
42	3,5	16,3	82	1,0	70	1,0
50	3,5	16,3	98	1,0	86	1,0
52	3,5	16,3	102	1,0	90	1,0
66	2,0	28,6	130	1,0	118	1,0

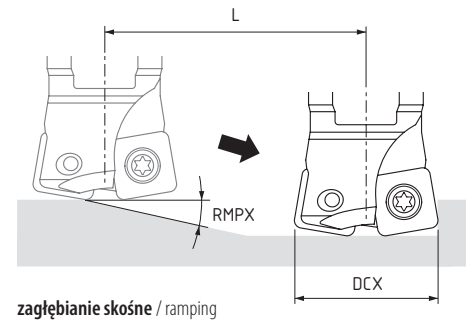

zagłębienie skośne / ramping

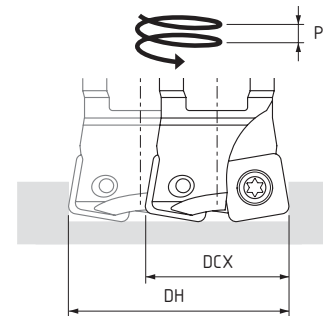

interpolacja śrubowa / helical interpolation

Stosowany kąt zagłębienia skośnego powinien być poniżej RMPX / Ramping angle used should be under RMPX.
Szybkość posuwu powinna być mniejsza niż 70% wskazanych wartości / Feed rate should be under 70% of indicated values.
*Minimalny dystans frezowania przy maksymalnym kącie pochylenia do momentu, gdy głębokość skrawania osiągnie APMX (1,0 mm) / Minimum distance made by cutter until depth of cut reaches APMX (1,0 mm) at maximum ramping angle.

Zagłębienie pionowe / Plunging

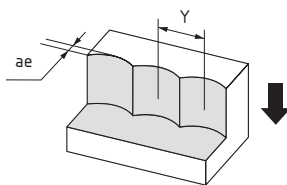

OAL ≤ 3DCX fz [mm/t]	OAL > 3DCX fz [mm/t]	Y max
0,08-0,15	0,05-0,10	$Y_{max} = \sqrt{DCX \times ae - ae^2}$

Y max i ae w zależności od średnicy skrawania DCX / Y max and ae corresponding cutting diameter DCX

DCX [mm]	20	25	32	35	40	42	50	52	66
ae [mm]	Y max [mm]								
1	4,4	4,9	5,6	5,8	6,2	6,4	7,0	7,1	8,1
2	6,0	6,8	7,7	8,1	8,7	8,9	9,8	10,0	11,3
3	7,1	8,1	9,3	9,8	10,5	10,8	11,9	12,1	13,7
4	8,0	9,2	10,6	11,1	12,0	12,3	13,6	13,9	15,7
5	8,7	10,0	11,6	12,2	13,2	13,6	15,0	15,3	17,5
6	9,2	10,7	12,5	13,2	14,3	14,7	16,2	16,6	19,0

Uwaga: dla bardzo długich narzędzi, gdy OAL ≥ 4DCX, zalecane jest zredukowanie wartości Y i ae.
Note: for very long tools, when OAL ≥ 4DCX, it is recommended to reduce the Y and ae values.



HFMIII 141



głowice nasadzone / arbor type cutters

GN141

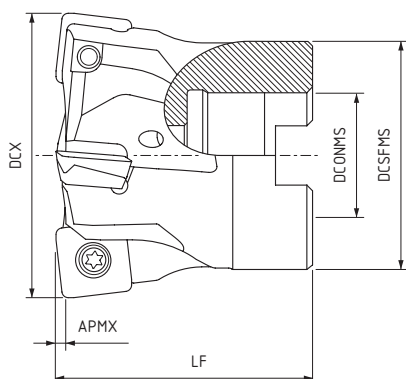

ID Polcomm® Polcomm® ordering number	DCX [mm]	DCONMS [mm]	DCSFMS [mm]	LF [mm]	ZEFP	APMX [mm]	typ mocowania arbor type	chłodzenie cooling	WT [kg]	plytka insert	dostępność stock
GN141 050A22 04504I	50	22	40	45	4	1,5	A	●	0,28	SO.. 13M5..	●
GN141 050A22 04505I	50	22	40	45	5	1,5	A	●	0,26	SO.. 13M5..	●
GN141 052A22 04504I	52	22	40	45	4	1,5	A	●	0,30	SO.. 13M5..	●
GN141 052A22 04505I	52	22	40	45	5	1,5	A	●	0,28	SO.. 13M5..	○
GN141 063A27 05005I	63	27	48	50	5	1,5	A	●	0,50	SO.. 13M5..	●
GN141 063A27 05006I	63	27	48	50	6	1,5	A	●	0,48	SO.. 13M5..	○
GN141 066A27 05005I	66	27	48	50	5	1,5	A	●	0,55	SO.. 13M5..	●
GN141 066A27 05006I	66	27	48	50	6	1,5	A	●	0,50	SO.. 13M5..	○
GN141 080A27 05006I	80	27	60	50	6	1,5	A	●	0,96	SO.. 13M5..	●
GN141 080A27 05007I	80	27	60	50	7	1,5	A	●	0,92	SO.. 13M5..	○
GN141 100A32 05008I	100	32	70	50	8	1,5	A	●	1,50	SO.. 13M5..	●
GN141 100A32 05009I	100	32	70	50	9	1,5	A	●	1,40	SO.. 13M5..	○



głowice wkręcane / screw type cutters

GW141

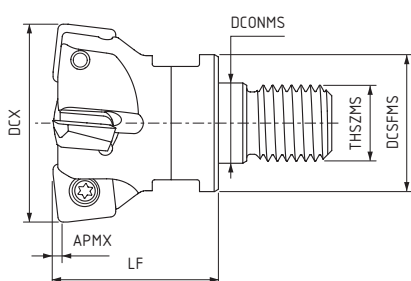





ID Polcomm® Polcomm® ordering number	DCX [mm]	DCONMS [mm]	DCSFMS [mm]	LF [mm]	THSZMS	ZEFP	APMX [mm]	chłodzenie cooling	WT [kg]	plytka insert	dostępność stock
GW141 032M16 03503I	32	17	29	35	M16	3	1,5	●	0,15	SO.. 13M5..	●
GW141 035M16 03503I	35	17	29	35	M16	3	1,5	●	0,16	SO.. 13M5..	●
GW141 040M16 03504I	40	17	29	35	M16	4	1,5	●	0,18	SO.. 13M5..	●
GW141 042M16 03504I	42	17	29	35	M16	4	1,5	●	0,19	SO.. 13M5..	●

● dostępne / on stock ○ na zamówienie / available on request



Części zamienne / Spare parts

				
zakres średnic diameter range	śruba screw	klucz wrench	zalecany moment dokręcenia recommended torque	śruba mocująca mounting screw
G. 141 032... - G. 141 080...	N01-003132	N01-003222	4,0 Nm	-
GN141 100...	N01-003132	N01-003222	4,0 Nm	N01-003695

S0..13

plytki frezarskie / milling inserts



SOGW 13M510 PMZ



SOEX 13M520 MMS

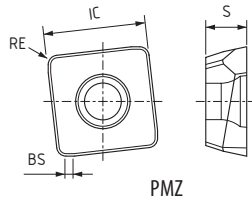

PMZ

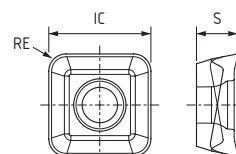

MMS

P	●	⚡	●	
M			●	●
K	●	⚡		
N				
S			●	
H				

- obróbka stabilna / stable cutting
- obróbka ogólna / general cutting
- ⚡ obróbka niestabilna / unstable cutting

oznaczenie designation	PC228	PC230	PC828	PC830	IC [mm]	S [mm]	BS [mm]	RE [mm]	APMX [mm]
SOGW 13M510 PMZ	46468 ●	28866 ●			12,4	5,0	1,0	1,2	1,5
SOEX 13M520 MMS			83894 ●	98081 ●	12,4	5,0	-	2,0	1,5

● dostępne / on stock ○ na zamówienie / available on request



parametry techniczne / technical parameters



Zalecane parametry skrawania / Recommended cutting conditions

ISO	obrabiany materiał work material	twardość hardness	gatunek Polcomm® Polcomm® grade	Vc [mm/min]	geometria geometry	fz [mm/t]
P	stale niestopowe non-alloy steel	125-220 HB	PC228	180-250	PMZ	0,5-2,2
			PC230	160-230	PMZ	0,5-2,2
			PC828	180-250	MMS	0,4-1,8
	stale niskostopowe low-alloy steel	220-280 HB	PC228	160-240	PMZ	0,5-2,2
			PC230	150-190	PMZ	0,5-2,1
			PC828	160-240	MMS	0,4-1,8
	stale wysokostopowe high-alloy steel	280-380 HB	PC228	140-220	PMZ	0,5-2,2
			PC230	140-180	PMZ	0,5-2,1
			PC828	140-220	MMS	0,4-1,8
M	stale nierdzewne martenzytyczne i ferrytyczne martensitic and ferritic stainless steel	200-330 HB	PC828	160-220	MMS	0,4-1,3
			PC830	140-210	MMS	0,4-1,3
	stale nierdzewne austenityczne austenitic stainless steel	200-330 HB	PC828	140-190	MMS	0,4-1,3
			PC830	120-170	MMS	0,4-1,3
	stale nierdzewne austenityczno-ferrytyczne stainless steel austenitic-ferritic (duplex)	230-260 HB	PC828	120-170	MMS	0,1-1,0
			PC830	100-150	MMS	0,1-1,0
K	żeliwa szare grey cast iron	130-230 HB	PC228	140-270	PMZ	0,5-2,2
			PC230	120-250	PMZ	0,5-2,2
	żeliwa sferoidalne nodular cast iron	160-250 HB	PC228	120-210	PMZ	0,5-2,2
			PC230	100-190	PMZ	0,5-2,2
S	stopy żaroodporne heat-resistant alloys	200-320 HB	PC830	30-110	MMS	0,4-1,3

Uwagi: / Notes:

Powyzsze parametry skrawania podano w celach informacyjnych. / Cutting conditions are just for reference.

Warunki skrawania są ograniczone przez sztywność przedmiotu obrabianego, moc maszyny i wysięg narzędzia. Gdy szerokość skrawania, głębokość lub długość wysięgu jest duża, należy ustawić Vc i fz na minimalną zalecaną wartość i sprawdzić wibracje oraz moc maszyny. / Cutting conditions are limited by workpiece rigidity, machine power and tool overhang. When the cutting width, depth or overhang length is large, set Vc and fz to the minimum recommended value and check vibrations and machine power.

W przypadku frezowania ze zmienną głębokością skrawania (na przykład na powierzchni odlewu) lub na nierównych powierzchniach, wartość posuwu (fz) należy zredukować do niższej zalecanej wartości podanej w tabeli powyżej. / When operation occurs with variable depth of cut (for example over casting skin) or over interrupted surfaces, feed value (fz) should be reduced to the lower recommended value shown in the table above.

Aby zapobiec zakleszczaniu się wiórów, ich nadmiar z obszaru roboczego należy usuwać strumieniem powietrza. / Excess of chips should be removed from working area with air blast to prevent chip jamming.



Geometria narzędzi do celów programowania / Programming data

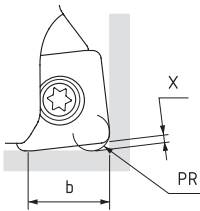

plytka / insert	PR [mm]	X [mm]	b [mm]
SO.. 13M5..	2,5	1,1	10,5

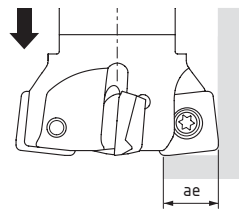

zagłębienie pionowe / plunging

plytka / insert	max ae [mm]
SO.. 13M5..	10,0

Zagłębienie skośne i interpolacja śrubowa / Ramping & helical milling

zagłębienie skośne ramping			interpolacja śrubowa (otwór nieprzelotowy z płaskim dnem) helical interpolation (blind hole, flat bottom)			
DCX [mm]	RMPX [°]	L [mm]*	DH max [mm]	P max [mm]	DH min [mm]	P max [mm]
32	10,0	6,0	62	1,5	43	1,5
35	9,0	9,5	68	1,5	49	1,5
40	6,6	13,0	78	1,5	59	1,5
42	6,4	13,4	63	1,5	63	1,5
50	4,3	19,9	79	1,5	79	1,5
52	4,0	21,5	83	1,5	83	1,5
63	3,0	28,6	105	1,5	105	1,5
66	2,6	33,0	111	1,5	111	1,5
80	2,0	43,0	139	1,5	139	1,5
100	1,0	85,9	179	1,5	179	1,5

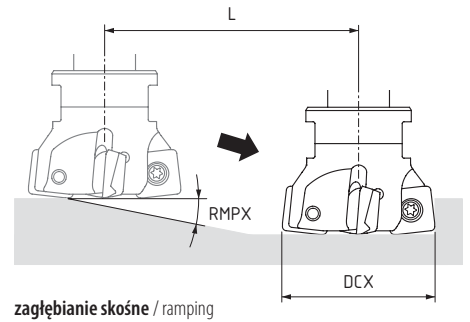

zagłębienie skośne / ramping

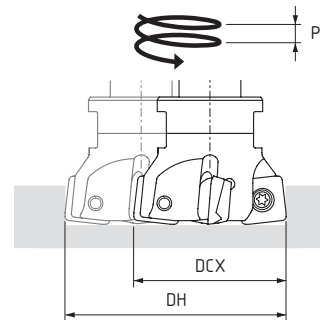

interpolacja śrubowa / helical interpolation

Stosowany kąt zagłębienia skośnego powinien być poniżej RMPX / Ramping angle used should be under RMPX.

Szybkość posuwu powinna być mniejsza niż 70% wskazanych wartości / Feed rate should be under 70% of indicated values.

*Minimalny dystans frezowania przy maksymalnym kącie pochylecia do momentu, gdy głębokość skrawania osiągnie APMX (1,5 mm) / Minimum distance made by cutter until depth of cut reaches APMX (1,5 mm) at maximum ramping angle.

Zagłębienie pionowe / Plunging

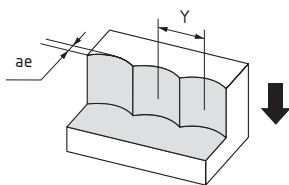

OAL ≤ 3DCX fz [mm/t]	OAL > 3DCX fz [mm/t]	Y max
0,1-0,2	0,08-0,12	$Y_{max} = \sqrt{DCX \times ae - ae^2}$

Y max i ae w zależności od średnicy skrawania DCX / Y max and ae corresponding cutting diameter DCX

DCX [mm]	32	35	40	42	50	52	63	66	80	100
ae [mm]	Y max [mm]									
1	5,6	5,8	6,2	6,4	7,0	7,1	7,9	8,1	8,9	9,9
2	7,7	8,1	8,7	8,9	9,8	10,0	11,0	11,3	12,5	14,0
3	9,3	9,8	10,5	10,8	11,9	12,1	13,4	13,7	15,2	17,1
4	10,6	11,1	12,0	12,3	13,6	13,9	15,4	15,7	17,4	19,6
5	11,6	12,2	13,2	13,6	15,0	15,3	17,0	17,5	19,4	21,8
6	12,5	13,2	14,3	14,7	16,2	16,6	18,5	19,0	21,1	23,7
7	13,2	14,0	15,2	15,7	17,3	17,7	19,8	20,3	22,6	25,5
8	13,9	14,7	16,0	16,5	18,3	18,8	21,0	21,5	24,0	27,1
9	14,4	15,3	16,7	17,2	19,2	19,7	22,0	22,6	25,3	28,6
10	14,8	15,8	17,3	17,9	20,0	20,5	23,0	23,7	26,5	30,0

Uwaga: dla bardzo długich narzędzi, gdy OAL ≥ 4DCX, zalecane jest zredukowanie wartości Y i ae.
Note: for very long tools, when OAL ≥ 4DCX, it is recommended to reduce the Y and ae values.

Polcomm® Mill Solutions

Przegląd rozwiązań frezarskich Polcomm® Polcomm® milling solutions overview







Polcomm® FCMill

seria rozwiązań Polcomm®
dedykowana do frezowania czołowego
series of Polcomm® solutions dedicated for face milling

seria / series	głowice frezarskie / milling cutters			phytki / inserts
FCMill 130	GN130			SNMX12 
	GN130			ONMU12 
FCMill 104	GN104			SEH.12 

Polcomm® SQMill

seria rozwiązań Polcomm®
dedykowana do frezowania walcowo-czołowego
series of Polcomm® solutions dedicated for shoulder milling

SQMill 149	GN149	GT149	GTJ149	AOMT 06 
	GN151	GW151	GT151	AOMT 11 
SQMill 101	GN101	GNJ101	GNF101	APKT 10 
	GT101	GTJ101	GTW101	
SQMill 102	GN102	GNJ102	GNF102	APKT 16 
	GT102	GTJ102	GTW102	
SQMill 111	GN111	GT111		WNEU 04 
SQMill 112	GN112			WNEU 08 

Polcomm® PRMill

seria rozwiązań Polcomm®
dedykowana do frezowania profilowego
series of Polcomm® solutions dedicated for profile milling

PRMill 191	GN191	GW191	GT191	RDMT 10 
PRMill 192	GN192	GW192	GT192	RDMT 12 
PRMill 193	GN193	GW193		RDMT 16 

Polcomm® FNMill

seria rozwiązań Polcomm®
dedykowana do obróbki wykańczającej
series of Polcomm® solutions dedicated for finishing

FNMill 153	GW153	GT153		CPHX 05 
FNMill 154	GN154	GW154	GT154	CPHX 08 

GN głowica nasadzana / arbor type cutter
GNJ głowica nasadzana jeżowa / arbor type helical cutter
GNF głowica nasadzana fazująca / arbor type chamfer cutter
GW głowica wkręcana / screw type cutter

GT głowica trzpieniowa / shank type cutter
GTJ głowica trzpieniowa jeżowa / shank type helical cutter
GTW głowica trzpieniowa wierząco-frezująca / shank type plunge cutter

Polcomm® HFMill

F R E Z O W A N I E / M I L L I N G

Cztery efektywne rozwiązania Polcomm® HFMill do szybkich posuwów.
Four effective Polcomm® HFMill solutions for high-feed milling.



HFMill 150

HFMill 209

HFMill 140

HFMill 141



speed up >
with us!

Polcomm® HFMill Solutions

AVIATION VALLEY

TOOL SERVICE



POLCOMM®

P.H.M. POLCOMM® Dariusz Kozak
Chlewiska 100, 21-100 Lubartów, Poland
tel./fax + 48 81 855 33 43
info@polcomm.com.pl



www.polcomm.com.pl