



Production Security.

- Inductive Metal Detectors
- Inductive Metal Separators
- Magnetic Separators



**Optimum
Productivity
in the
Plastics Industry**

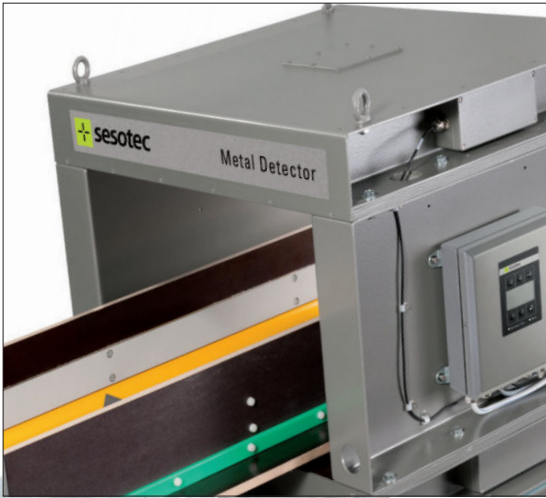

Metal Separation - Systematically.

Professional Solutions for all Production Stages and Conveyor Types

secure.



Process security in plastics processing. For over 40 years Sesotec has been providing the plastics industry with cost-effective, tried and tested solutions. We cover every stage in the process – from manufacturing granulate through to finished products and on to recycling.

Sesotec metal detectors and separators identify and remove all metals, not only magnetic but stainless steel, aluminium, copper, brass and lead; irrespective of whether they are in pure form, bonded, coated, lacquered, insulated or even embedded in other materials.

Magnetic separators are an effective complement in the pre-removal of ferrous metal and magnetic steel particles.

Sesotec develops individual machines and systems in close cooperation with its customers; the result is effective and consistent operation, easy installation and commissioning with minimal maintenance requirements.

Effective and reliable detection and removal of

- magnetic metals
- non-magnetic metals (copper, brass, stainless steel etc)

Additional benefits

- reliable machine protection
- increased productivity
- reduced reject products
- increased product quality

Seamless integration

- into every stage of the process
- into every type of conveying system
- plug and play board replacement
- customised design

Highly developed technology

- product effect compensation
- digital signal processing
- automatic teach-in
- multi-product memory
- simple to operate

Total project support

- project consultation and analysis
- product trials and test machinery
- training and seminars
- worldwide after-sales service

Separating magnetic and non-magnetic metals

Granulate production

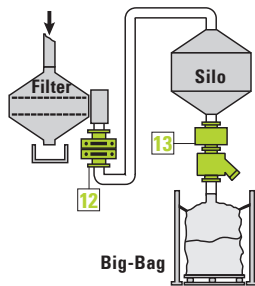

Grinding



Material Stock

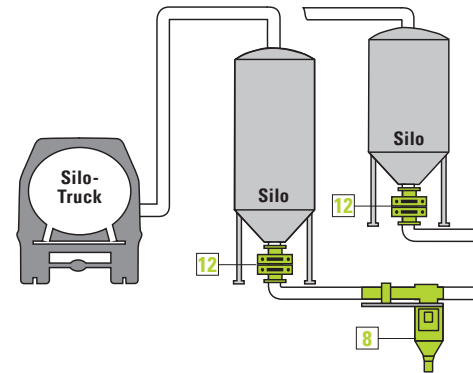

Metal-free sprue and parts recycling

Sesotec metal detectors are widely used in the reprocessing of production waste (in-house recycling) or in specialist recycling facilities. They can be built into feeder conveyors to protect downstream milling machinery. Additionally they prevent larger pieces of metal from being shredded and thereby prevent tiny fragments of metal being spread throughout the granulate.



1 RAPID VARIO-FS Metal Separator
Compact free-fall separation system. Metal contaminants are rejected via the rejection flap of the "Quick Flap System" without disrupting the material flow.



2 RAPID PRO-SENSE 4 Metal Separator
Metal separator with highest scanning sensitivity for all metals, installed at the outlet of a cyclone (free-fall application).



3 RAPID DUAL Metal Separator
Metal separator used to inspect slowly moving bulk material such as foil flakes as well as large streams.

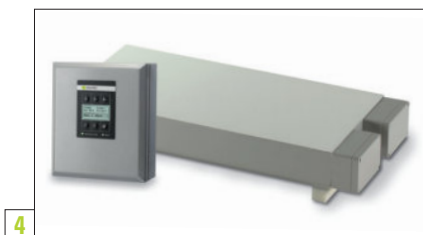

4 ELS Metal Detector
Single face ELS metal detectors are installed directly underneath the belt of a conveyor where the depth of conveyed material is shallow ie close to the belt. A typical application is the inspection of sprues to protect auger granulators. ELS can also be used to inspect the quality of plastic components to ensure the core is not broken.



5 ELCON Metal Detector
Suitable for small conveyor belts and materials up to 100 mm height.



6 Metal detector DLS and DLS-R
Separable tunnel metal detectors of type DLS and DLS-R can be installed in (existing) conveyor belts and guarantee highest detection accuracy throughout the whole aperture area. DLS metal detectors typically are used for the protection of cutting mills and shredders.

Conveying

Production

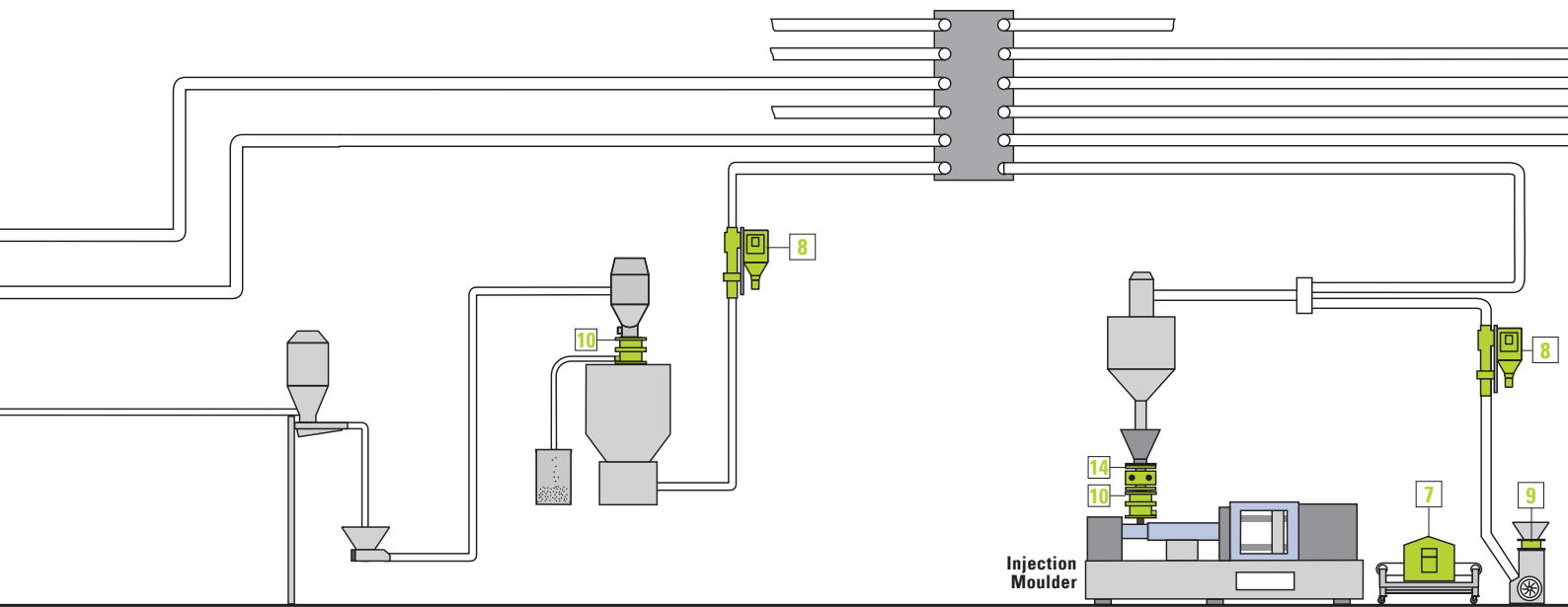

Metal-free material handling in pipelines

Metal separators are often used in freefall applications and pneumatic conveying pipelines. A specially-designed, fast-reacting reject flap ("Quick Flap System") removes metal contamination from bulk materials with minimal loss of good material. Magnetic separators installed in pipelines work as stand-alone devices or to support inductive metal separators.



8

GF Metal Separator

These metal separators are designed to be installed in horizontal, vertical or inclined vacuum and pressure pipes. Detection and removal of contaminants is effective even at high speeds and rejected material is removed into a container with no interruption to material flow.



9

P-SCAN Metal Detector

Metal detector can be installed in pipelines e.g. for free-fall applications, pneumatic or vacuum pipelines. Extremely compact through its reduced metal-free zone.



10

Metal separators of the PROTECTOR series

Metal separators for applications with lower material throughput rates that are installed at the inlet of processing machines. The PROTECTOR series covers various application fields – standard, highest scanning sensitivity, or high temperature applications.



7

GLS and GLS-R Metal Detector

Conveyor belt metal detector with high sensitivity to detect bead wire breaks in plastic particles.

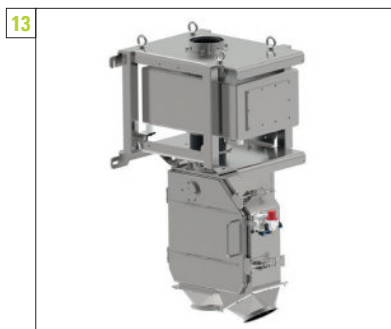

13

RAPID PRO-SENSE 6 Metal Separator

Metal separator with highest scanning sensitivity for all metals due to innovative HRF technology (High Resolution Frequency). The modular system design allows optimal adaptation to customer- and material-specific requirements.



14

SAFEMAG Inline magnet

The compact and sturdy design (60 mm) guarantees secure separation without abrasion.

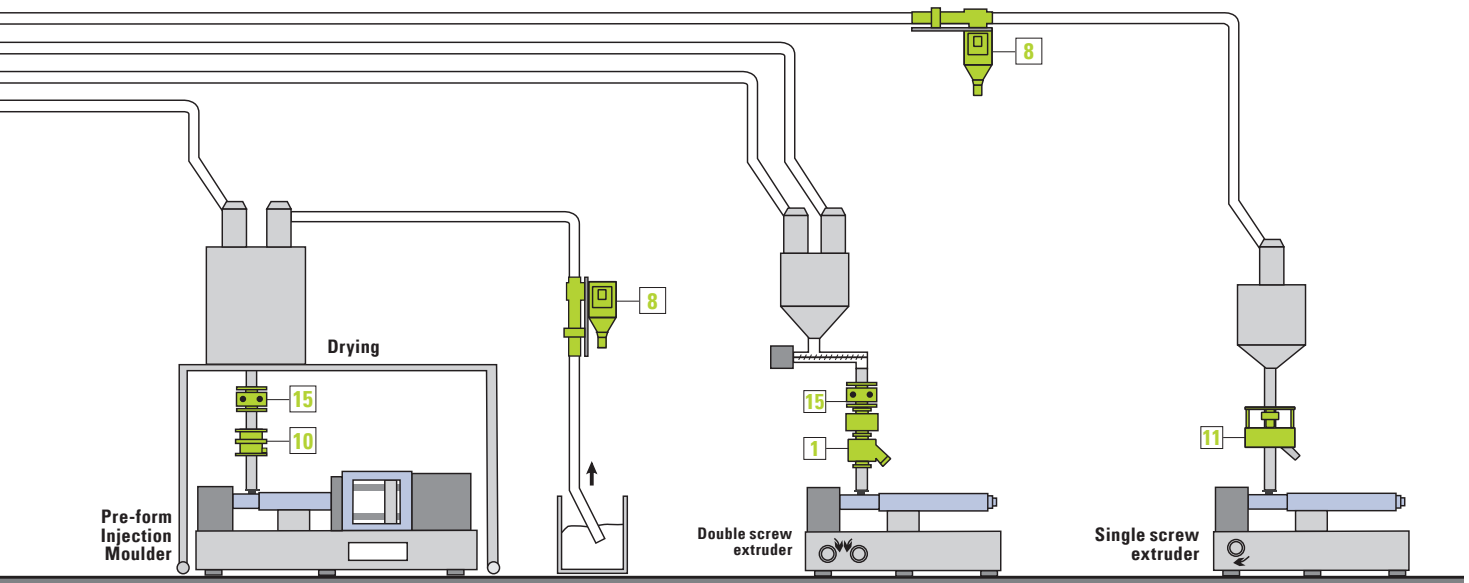

Metal-free extruding, injection and blow moulding

The following inline magnets and metal separators are installed directly at the material infeed of extruders, injection moulding and blow moulding machinery and remove metal particles from a slowly downward-moving column of material. However they will also consistently remove metals from free-falling granulate, not only at the initial fill but also at subsequent top-ups. They provide maximum machine protection ("Last Chance Controller") and prevent metering screw failures, nozzle blockages and damage to tooling. Due to their compact design, heavy conveying, mixing or dosing equipment can be attached to these units.



Metal Separator PROTECTOR-MF

This range of equipment is primarily for processing machinery with larger material infeeds and therefore higher throughputs. The pneumatically-driven reject system guarantees effective and reliable separation.



MAGBOX Inline magnet

Magnet system to separate even smallest contaminants; Easy integration into existing pipelines.

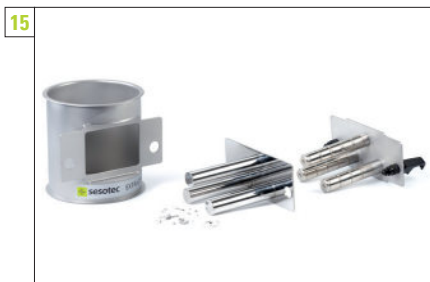

EXTRACTOR-J Inline magnet

Magnetic separator for Jacob pipelines; Inspects granulates of up to 10 mm.

Separating and Sorting Systems

Professional solutions for plastics recycling



Over more than three decades Sesotec has become one of the leading manufacturer of contaminant separation and sorting systems. For the recycling industry Sesotec has developed a range of individual machines and complete solutions to remove contaminants from plastic or to sort mixed material flows into pure fractions. They play a pivotal role in ensuring that highly pure recycled material can be profitably reprocessed back into the production cycle. In the PET industry Sesotec systems achieve recycling rates approaching 100 %.

Sesotec offers a full range of equipment for contaminant separation – from basic sorting through to precision separation applications. As well as removing magnetic and non-magnetic metals Sesotec systems sort plastics according to type and color. Near infra-red sensors, color and shape sensors and metal sensors are utilized for effective and reliable detection.

Sesotec systems are built to a well-proven modular design concept to ensure that exactly the right combination of components is chosen to meet the customer's specific application.



FLAKE PURIFIER+
Multi-sensor system for plastics recycling

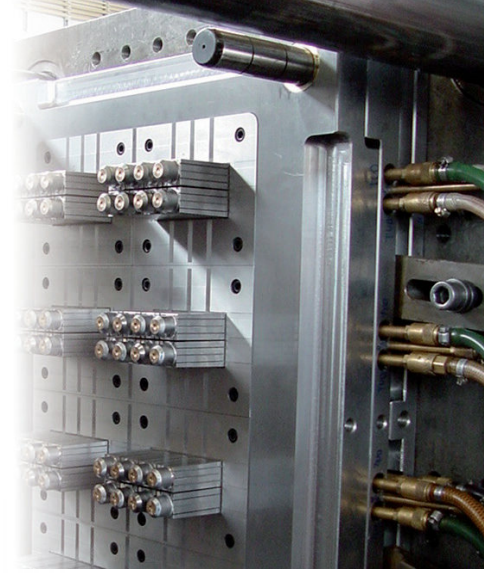
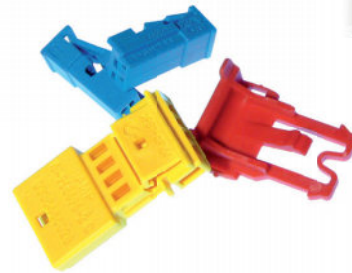

Tool and Machinery Protection.

Increased production security and optimum machine utilisation

In plastics processing Sesotec metal detectors and separators are primarily employed to protect processing machinery. They help prevent breakdowns and therefore increase productivity and continuity, providing a very fast return on investment.

Sesotec metal separation systems protect extruders, injection and blow moulding machinery from the effects of metal contaminants in both virgin and particularly recycled granulate. Plasticizer screws and cylinders are securely protected from damage. Extruder and blow moulding machinery breakdowns and downtimes caused by blockages to melt filters and nozzle systems are considerably reduced. Injection moulding machinery is protected from damage to tooling, hot channels and reverse flow barriers.

Sesotec metal detectors prevent damage to milling machinery and colander rollers. For bulk material or packaged product inspection Sesotec units are integrated into conveyor systems.

Quality Assurance.

Minimum rejected product and maximum added value

Sesotec metal detection and separation systems guarantee the purity of plastics products and play a vital role in the quality assurance process.

Metal contaminants can block hot channels and cause rejects through under-injection. Metal separation systems prevent this and guarantee first class products. Melt stress (encrustation) is also considerably reduced by the use of metal separators. Less rejected product means less cost and more customer satisfaction.



Sesotec GmbH

Regener Straße 130
D-94513 Schönberg
Germany
Tel. +49 8554 308-0
Fax +49 8554 2606
info@sesotec.com
www.sesotec.com

Sesotec system world



Detecting and separating contaminants

- Removing contaminants:
- metals
 - plastics
 - glass
 - ceramics, porcelain, stones
 - and many others
- Removing from (good material):
- bulk materials
 - liquids and pastes
 - individually packaged product
 - packed and loose items
- Product types
- end-products (food, textiles, plastics etc)
 - industrial raw materials
 - recycled materials
- can be integrated into all types of conveyor systems



Detecting and separating sub-standard products

- Qualitative defects:
- incorrect colour
 - agglomerations
 - breakages
 - air inclusions in packs
 - incorrect positioning / distribution
- Quantitative defects:
- incorrect weight
 - count errors (incorrect number of items in package)
- Product types
- end-products (food, textiles, plastics etc)
 - industrial raw materials
 - recycling materials
- can be integrated into all types of conveyor systems



Sorting mixed materials into single fractions

- Types of material:
- glass
 - plastics
 - metals
 - and many others
- Delivery flows:
- bulk materials
 - individually packaged product
- can be integrated into:
- conveying systems
 - bulk material flows

Operating Companies:



Sesotec Inc.
Bartlett
USA
info@sesotec.us
www.sesotec.us



Sesotec Canada Ltd.
Guelph
Canada
servicecanada@sesotec.ca
www.sesotec.ca



Sesotec Pte. Ltd.
Singapore
info@sesotec.com.sg
www.sesotec.com.sg



Sesotec Pvt. Ltd.
Pune
India
info.india@sesotec.com
www.sesotec.com



Sesotec Shanghai Co. Ltd.
Shanghai
China
enquiry@sesotec.com.cn
www.sesotec.com.cn



Sesotec Thailand Ltd.
Bangkok
Thailand
info@sesotec.com
www.sesotec.com

... and more than 40 agencies worldwide

Made in Germany

For further information or to discuss your particular application contact one of our specialists.

www.sesotec.com



**Choose the Original
Choose Success!**

