

TECHNICAL SPECIFICATIONS

MODEL	CXE 3000	CXE 1500	CXM 3000	CXM 1500
Max Flow	3000 lt/min	1500 lt/min	3000 lt/min	1500 lt/min
Nominal Pressure	10 Bar	10 Bar	10 Bar	10 Bar
Max Pressure	17 Bar	17 Bar	17 Bar	17 Bar
Inlet	2.5"	2"	2.5"	2"
Outlet	2.5"	1.5"	2.5"	1.5"
Travel	-45+85/355	-45+85/355	-45+85/355	-45+85/355
Voltage	24V	24V	-	-
Control Communication	Can bus 2,4 Ghz Digital radio frequency (unlicensed)		-	-
Material	Aluminum	Aluminum	Aluminum	Aluminum
Weight	16 Kg	12.8 Kg	12.8 Kg	9.8 Kg

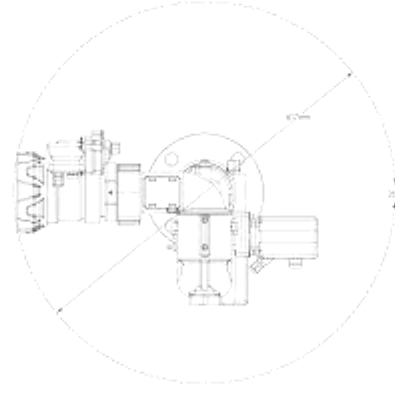
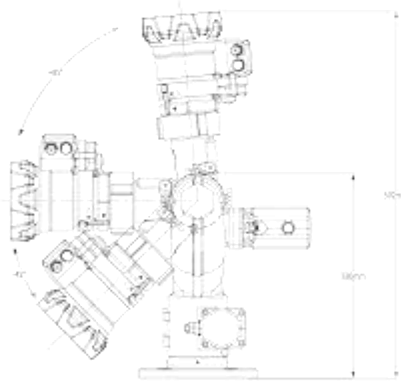
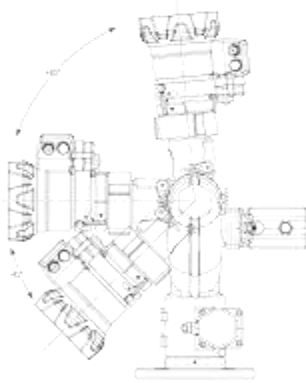

PUMA SERIES

CXE 150 | CXE 300
CXM 150 | CXM 300



TS EN 1028, Iso 9001, Iso 14001, Iso 18001, CE ve Gost-R



celiksanaracustu celiksan.co celiksan

www.celiksan.com

Ekrem Demirtaş Caddesi No: 37
İtob Organize Sanayi Bölgesi, 35868 Menderes / İzmir
+ 90 232 254 57 27 info@celiksan.com

SINCE 1976

 **CELIKSAN**
one brand

PUMA SERIES

CXE 150
CXE 300

PUMA SERIES

CXM 150
CXM 300



- Advanced design, multi-purpose use options
- Wide-angle design -45, +85
- The use of water and foam, nozzle with flow rate adjustment
- Electronic control unit with canbus technology
- IP 67 protection class
- Corrosion-resistant aluminum housing and nozzle
- Innovative body design that provides ease of installation
- Joystick, wireless Wifi cable and manual operation capability when desired

- Advanced design, multi-purpose use options
- Wide-angle design -45, +85
- The use of water and foam, nozzle with flow rate adjustment
- Electronic control unit with canbus technology
- IP 67 protection class
- Corrosion-resistant aluminum housing and nozzle
- Innovative body design that provides ease of installation
- Joystick, wireless Wifi cable and manual operation capability when desired