

# TRM

## Single shaft shredders

**Mod. TRM600**

**Mod. TRM900**

**Mod. TRM1200**

**Mod. TRM1500**



### Caratteristiche tecniche

- È stato realizzato e brevettato un nuovo sistema di fissaggio delle lame rotanti con inclinazioni di taglio che permettono il recupero di particolari impegnativi e alte produzioni con un consumo limitato di energia.
- Adatti per il recupero di materiali plastici, spurghi, film, particolari auto e inoltre cavi elettrici legno, carta, ecc.
- Dotati di un PLC appositamente studiato per gestire le diverse applicazioni, con possibilità di scelta tra differenti programmi di lavorazione automatica.

### Technical data

- A new system to fasten rotating blades has been built and patented, featuring cutting angles which help recycle difficult components and achieve high production levels with restricted energy consumption.
- Suitable to recover plastic materials, discharges, films, car parts and also electric cables, wood, paper, etc.
- Fitted with a PLC which has been adequately designed to manage different applications, with the chance to select among different automatic machining programs.

### applications



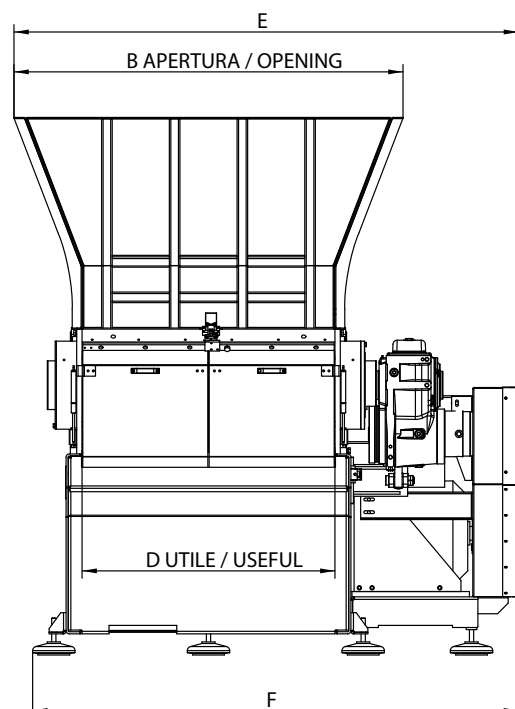
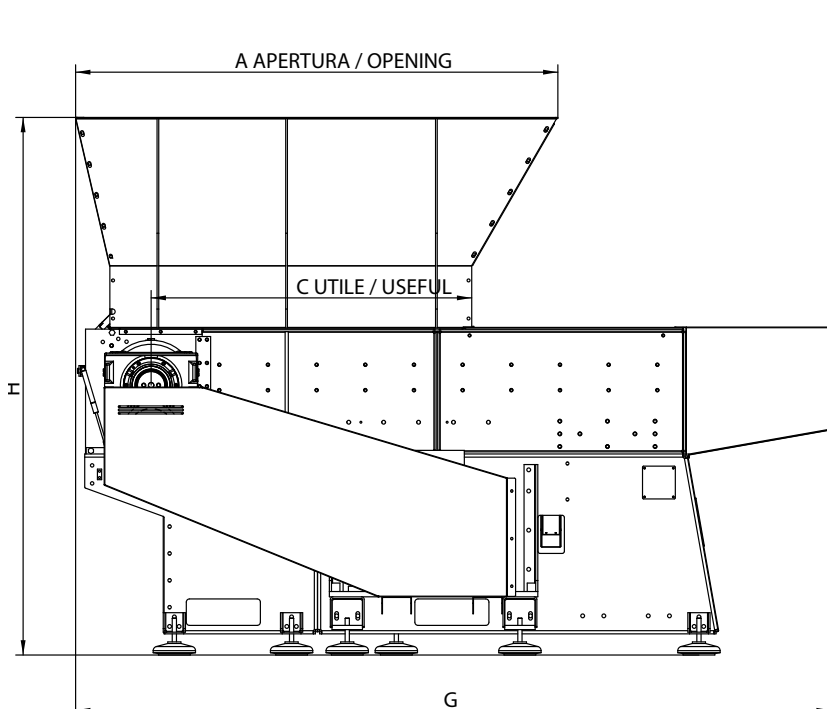

	A	B	C	D	E	F	G	H
<b>TRM600</b>	1204	1015	584	601	1432	1289	2003	1895
<b>TRM900</b>	1526	1311	906	897	1805	1720	2563	1980
<b>TRM1200</b>	2180	1732	1255	1194	2384*	2296*	3527	2540
<b>TRM1500</b>	2340	2109	1545	1495	-/-	2722**	4526	2412

\*VERSIONE 75KW E = 2437 F = 2348

\*\*VERSIONE DOPPIO MOTORE F = 3394

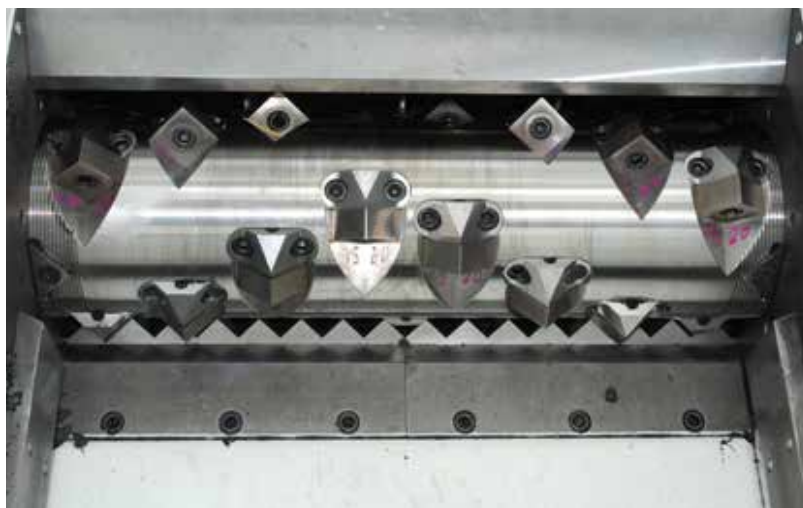

		TRM600	opt.	TRM900	opt.	TRM1200	opt.	TRM1500	opt.
Rotor diameter/Diametro rotore	∅ mm	220		220		400		400	
Rotor lenght/Lunghezza rotore	mm	600		900		1200		1500	
Rotor knives/Lame rotanti	n°	15	23	23	34	47	91/31	58	97
Speed rotor/Velocità rotore	rpm	105		105		105		110	
Motor power/Potenza motore	KW	18,5		30		55	75/2x55	75	2x55/2x75
Hydraulic system power/Potenza centralina idraulica	KW	1,1		1,1		4	5,5	5,5	

