

# GT Series

## Thermoforming Granulators

**Mod. GT26-70**

**Mod. GT26-92**

**Mod. GT30-92**

**Mod. GT30-122**



### Prestazioni & caratteristiche distintive

- Configurazione bassa per facile posizionamento
- Adatto a lastra, scheletrato e macinazione di pezzi
- Completamente insonorizzato per una bassa rumorosità di esercizio
- Massima produttività
- Dimensione uniforme del macinato con il minimo contenuto di polvere
- Camera di taglio assemblata con spine e bulloni
- Taglio tangenziale
- Orientamento griglia orizzontale

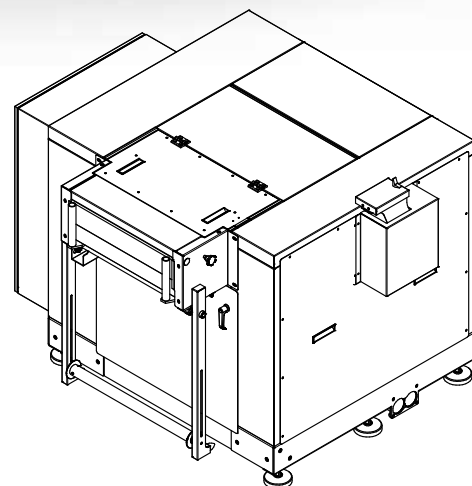

### Performance & Distinctive features

- Low profile configuration for easy positioning
- Suitable for sheet, skeletal sheet and parts grinding
- Quiet operation, fully sound insulated
- Highest regrind output capacity
- Uniform regrind dimensions with minimal dust content
- Bolt&Dowel cutting chamber assembly
- Tangential cutting design
- Horizontal screen orientation





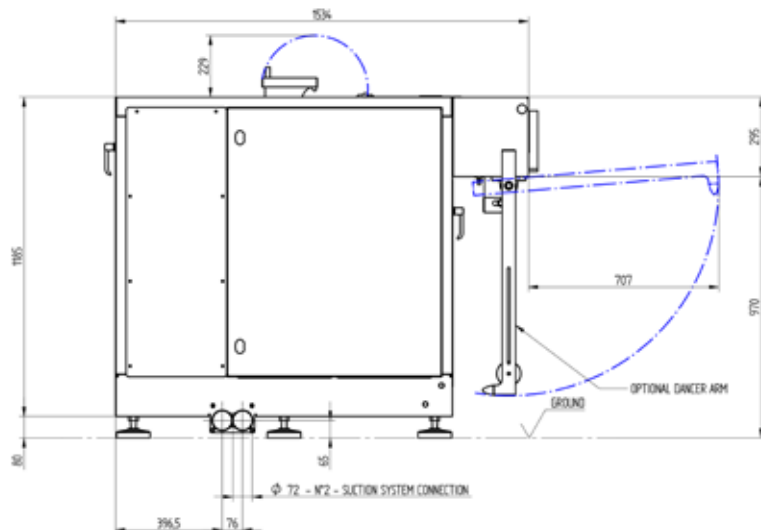
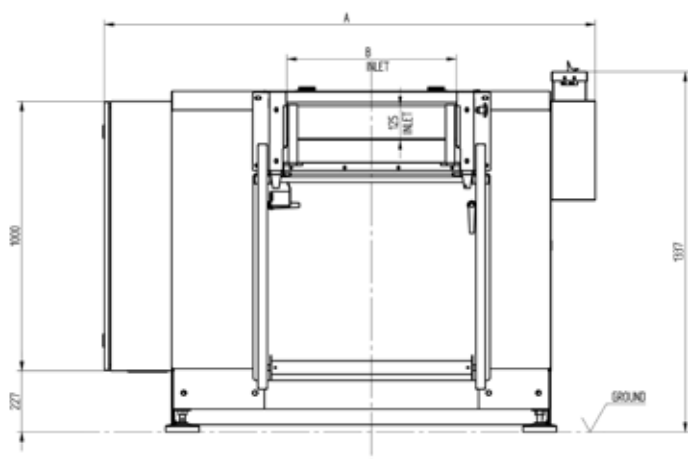

### applications



[cmg-granulators.com](http://cmg-granulators.com)



	A	B
<b>GT26-70</b>	1824	630
<b>GT26-92</b>	2043	849
<b>GT30-92</b>	2043	849
<b>GT30-122</b>	2344	1150

	 mm	 n°	 n°	 mm	 RPM	 KW	 Kg/H
<b>GT26-70</b>	630	3	2	254	510	7,5 (11-15)	150-400
<b>GT26-92</b>	850	3	2	254	510	7,5 (11-15)	200-500
<b>GT30-92</b>	850	3	2	300	510	11 (15)	300-600
<b>GT30-122</b>	1150	3	2	300	510	15	400-800



[cmg-granulators.com](http://cmg-granulators.com)