

# COMAV

bulk material handling valves

## COMAV



# CATALOGUE

**COMAV srl unipersonale**  
via Statale, 337  
44047 Terre del Reno (FE) - ITALY  
phone +39 0532 848348  
e-mail [info@comav-srl.com](mailto:info@comav-srl.com)  
web [www.comav-srl.com](http://www.comav-srl.com)

**ROTARY VALVES**

<b>VSD</b>	Drop through rectangular flange	<b>2</b>
<b>VSTD</b>	Drop through round flange	<b>4</b>
<b>VSF</b>	Blow through rectangular flange	<b>6</b>
<b>VSTF</b>	Blow through round flange	<b>8</b>
<b>VSFC</b>	Blow through rectangular flange	<b>10</b>
<b>ROTORS</b>		<b>12</b>
<b>ACCESSORIES</b>		<b>14</b>
<b>VERSIONS</b>	Detachable, High Temp, on Trolley, on Platform	<b>21</b>

**DIVERTER VALVES**

<b>DTS</b>	Static seal	<b>22</b>
<b>DTP</b>	Pressurized seal	<b>26</b>
<b>DT ACCESSORIES</b>		<b>28</b>
<b>DT VERSIONS</b>		<b>31</b>
<b>VDF</b>	Flexible pipe	<b>32</b>
<b>VDP</b>	Swinging pipe	<b>34</b>
<b>DTG2W</b>	Gravimetric 2 ways	<b>36</b>
<b>DTG3W</b>	Gravimetric 3 ways	<b>38</b>

**KNIFE VALVES**

<b>SGA1</b>	Single cylinder	<b>40</b>
<b>SGA2</b>	Double cylinder	<b>42</b>
<b>SGB</b>	Double blade	<b>44</b>
<b>SGM</b>	Emergency gate valve	<b>46</b>

**RELIEF VALVE**

<b>VPP</b>	Over Under pressure valve	<b>48</b>
------------	---------------------------	-----------

# OVERVIEW

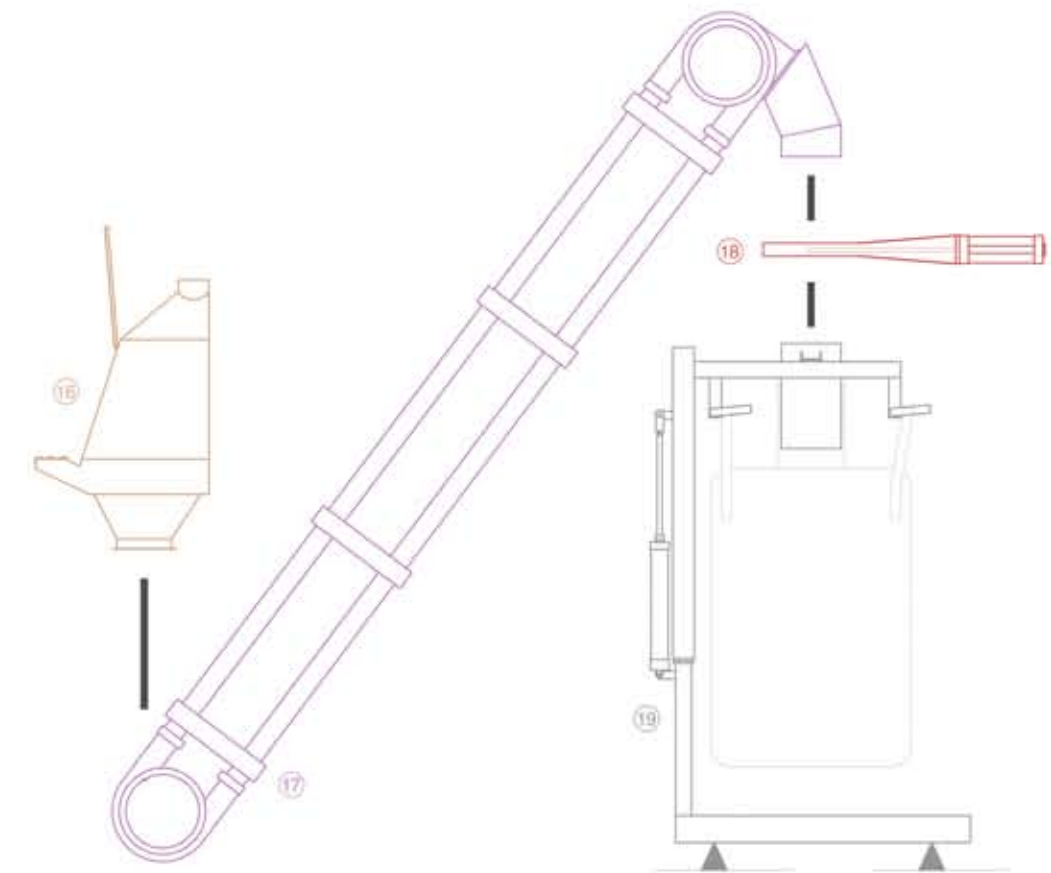
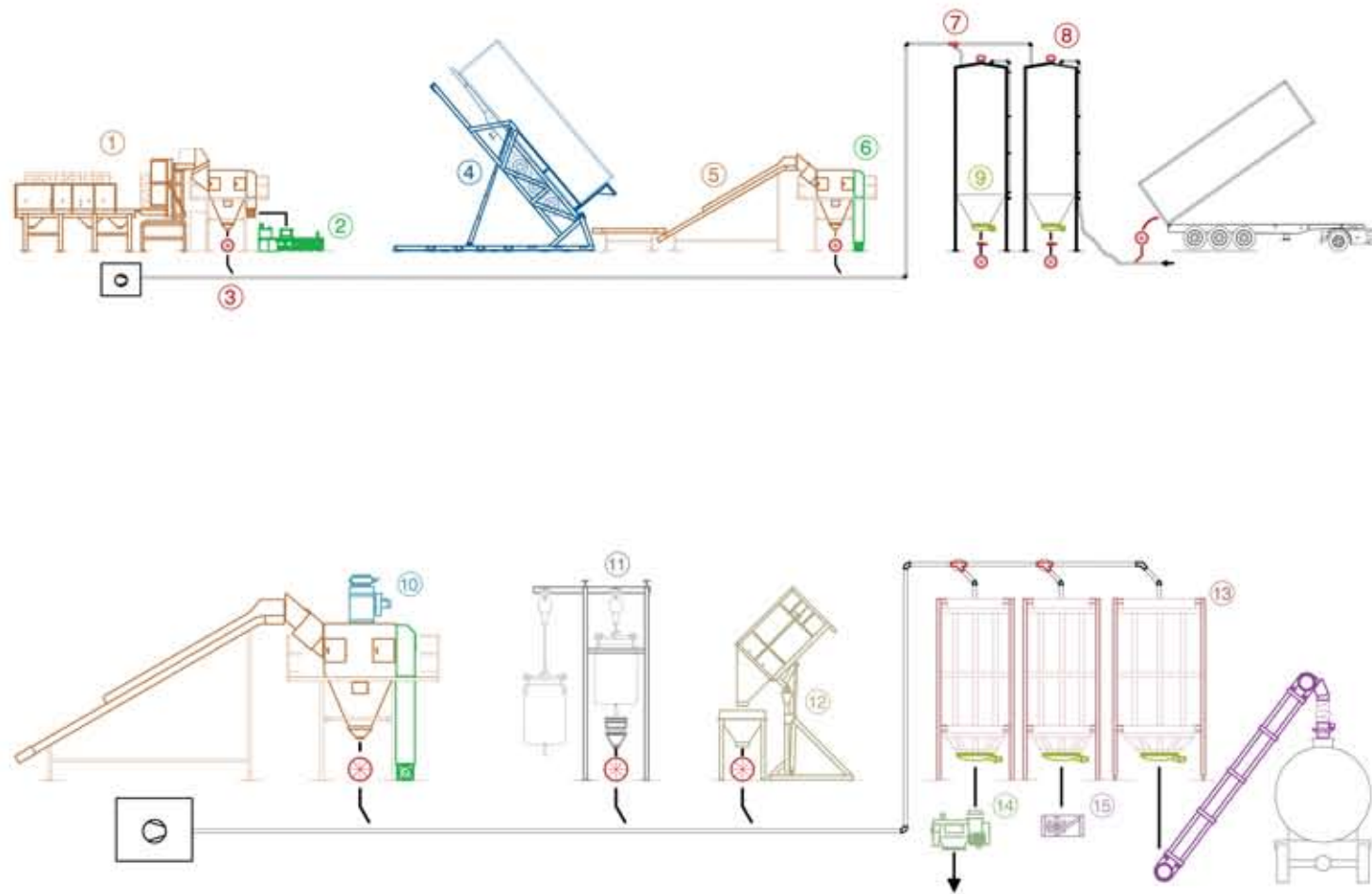

① BAG EMPTYING MACHINE WITH DEPALLETIZER

② BALING PRESS

③ ROTARY VALVE

④ TILTING STATION

⑤ BAG EMPTYING MACHINE WITH BELT CONVEYOR

⑥ EMPTY BAG PRESSING SCREW

⑦ DIVERTER VALVE

⑧ RELIEF VALVE

⑨ BIN ACTIVATOR

⑩ AIR JET FILTER

⑪ BIG BAG DISCHARGER

⑫ OCTA-BIN

⑬ TREVIRA SILO

⑭ SIFTER

⑮ LUMP BRAKER

⑯ MANUAL DEBAGGING UNIT

⑰ AERO CONVEYOR

⑱ KNIFE VALVE

⑲ FIBC

DROP THROUGH ROTARY VALVES are designed to handle pneumatic conveying in dilute and dense phase for every industrial application such as food, plastic, rubber, chemical, pharmaceutical and mining. Thanks to COMAV'S TECHNOLOGY our valve is used for powders, granules, flakes and pellets, assuring a perfect reliability and meeting a wide range of customer's requirements. The rectangular flange and a special disalignment allow a complete cell discharge without any breakage of the product



### APPLICATIONS

- METERING
- DISCHARGE
- POWDER
- GRANULE
- GENERAL PNEUMATIC CONVEYING
- MOCA – EC1935/2004

### DESIGN

- FLANGING: RECTANGULAR
- SIZE: 200,250,320,400,480
- HOUSING: CAST IRON CASTING, SS316L CASTING
- ROTOR: WELDED CARBON STEEL OR SS304, SS316L
- DRIVE: DIRECT DRIVE STANDARD VERSION OR CHAIN TRANSMISSION. AVAILABLE IN BARE SHAFT VERSION ALL OUR DRIVES CAN BE CONTROLLED BY INVERTER
- ROBUST&COMPACT DESIGN WITH MINIMAL ROTOR TOLERANCE

### FEATURES

- PRESSURE: 1,5 BAR
- TEMPERATURE: MAX 65 °C
- AIR LEAKAGE: SEE CHART
- INTEGRATED CASTING INNER HOPPER ( BETTER FILLING EFFICIENCY)
- 8 VANES OPEN OR CLOSED ENDS ROTOR

### OPTIONALS

- DIFFERENT ROTORS FOR DIFFERENT PRODUCTS
- NICKEL COATING EC1935/2004
- HARD CHROMIUM PLATING
- VARIOUS POLISHING DEGREES
- HIGH TEMPERATURE CONFIGURATION
- FEEDING SHOE
- FEEDING HOPPER COMPLETE WITH AIR INTAKES
- AIR BLOW-IN PURGE
- AIR INTAKE HOLE ON HOUSING
- SPEED DISPLAY
- SPEED CONTROLLER

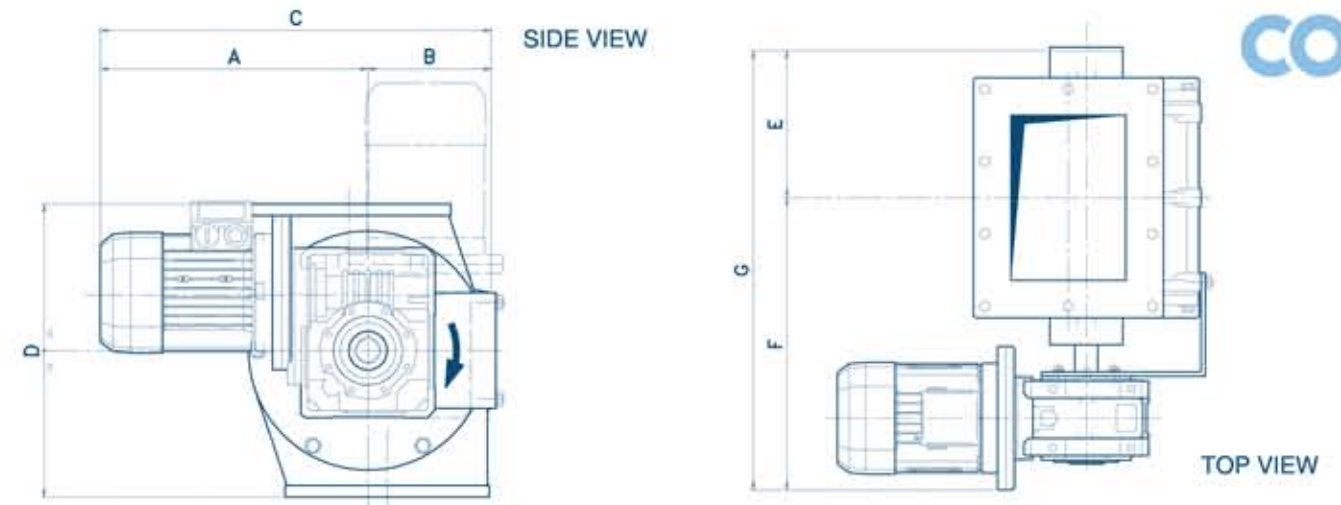
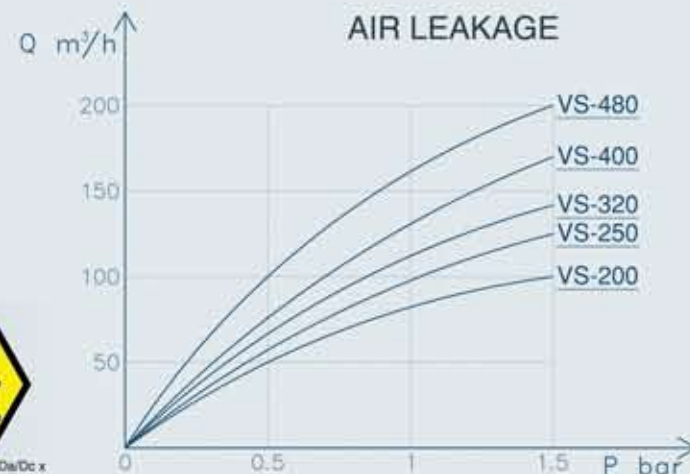

	A	B	C	D	E	F	G	L./Rev.	Rev./1' max	POWER	WEIGHT
200	350	130	480	320	190	380	570	4,5	30	Kw 0.55	Kg 80
250	350	160	510	380	205	395	600	8	30	Kw 0.55	Kg 106
320	380	195	575	450	221	421	642	16	30	Kw 1,10	Kg 176
400	400	240	640	570	280	482	762	37	30	Kw 1,50	Kg 282
480	430	305	735	660	315	517	832	65	30	Kw 2.20	Kg 538

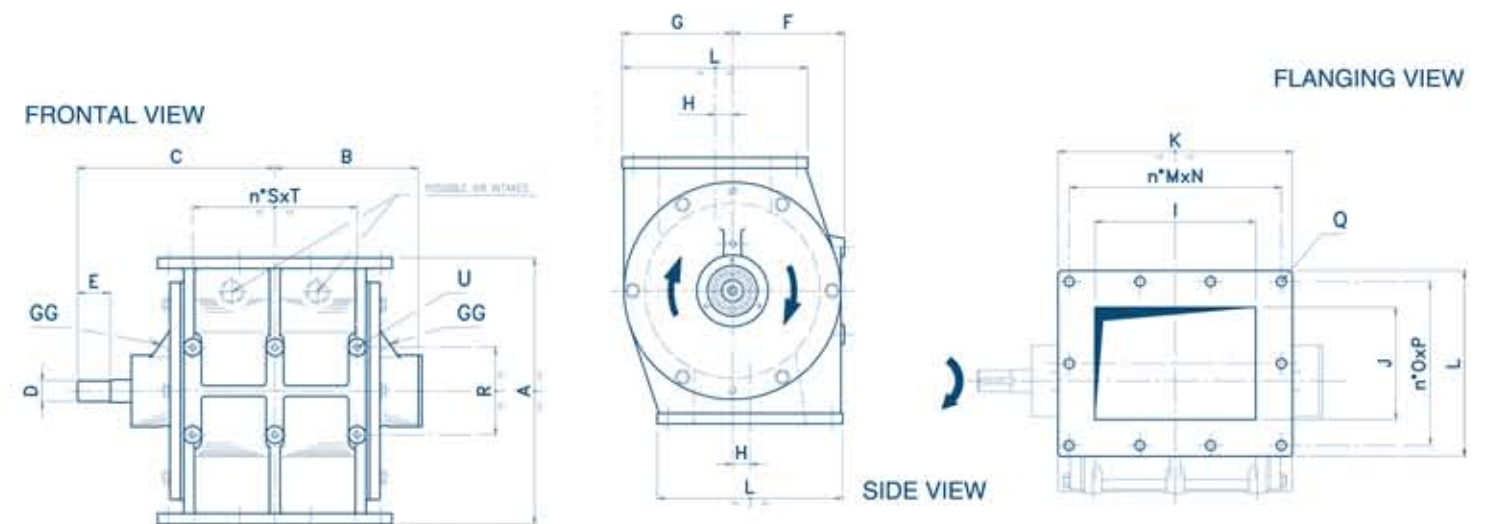

	A	B	C	D	E	F	G	H	I	J	K	L	M
200	320	190	267	ø30	47	130	132,5	20	200	140	285	225	3
250	380	205	282	ø30	47	160	157,5	25	230	160	335	265	3
320	450	221	304	ø35	53	195	192,5	40	260	200	365	305	3
400	570	280	368	ø40	56	240	237,5	55	370	260	475	365	4
480	660	315	405	ø52	65	305	282,5	70	444	300	570	425	4

	N	O	P	Q	R	S	T	U	L./Rev.	WEIGHT	GG
200	86	2	99	ø12	115	1	210	M10	4,5	Kg 64	1/8" GAS
250	101	2	117	ø14	125	2	117,5	M10	8	Kg 90	1/8" GAS
320	111	2	136	ø14	175	2	132,5	M10	16	Kg 147	1/8" GAS
400	110	2	165	ø14	220	3	125	M10	37	Kg 260	1/4" GAS
480	132	2	191	ø18	220	3	150	M10	65	Kg 492	1/4" GAS

BROCHURE



COMPLIANCE



II 1/30 IIC T135°C Da/Dc x

# VSTD DROP THROUGH ROTARY VALVE

DROP THROUGH ROTARY VALVES are designed to handle pneumatic conveying in dilute and dense phase for every industrial application such as food, plastic, rubber, chemical, pharmaceutical and mining. Thanks to COMAV'S TECHNOLOGY our valve is used for powders, granules, flakes and pellets, assuring a perfect reliability and meeting a wide range of customer's requirements. The round flange allows an easy connection to the conveying line and the equipment.



## APPLICATIONS

- METERING
- DISCHARGE
- POWDER
- GRANULE
- GENERAL PNEUMATIC CONVEYING
- MOCA – EC1935/2004

## DESIGN

- FLANGING: ROUND UNI 2277-67 PN 10
- SIZE: DN150, DN200, DN250, DN300
- HOUSING: CAST IRON CASTING SS316L
- ROTOR: WELDED CARBON STEEL OR SS304, SS316L
- DRIVE: DIRECT DRIVE STANDARD VERSION OR CHAIN TRANSMISSION. AVAILABLE IN BARE SHAFT VERSION ALL OUR DRIVES CAN BE CONTROLLED BY INVERTER
- ROBUST&COMPACT DESIGN WITH MINIMAL ROTOR TOLERANCE

## FEATURES

- PRESSURE: 1,5 BAR
- TEMPERATURE: MAX 65 °C
- AIR LEAKAGE: SEE CHART
- INTEGRATED CASTING INNER HOPPER ( BETTER FILLING EFFICIENCY)
- 8 VANES OPEN OR CLOSED ENDS ROTOR

## OPTIONALS

- DIFFERENT ROTORS FOR DIFFERENT PRODUCTS
- NICKEL COATING EC1935/2004
- HARD CHROMIUM PLATING
- VARIOUS POLISHING DEGREES
- HIGH TEMPERATURE CONFIGURATION
- FEEDING SHOE
- FEEDING HOPPER COMPLETE WITH AIR INTAKES
- AIR BLOW-IN PURGE
- AIR INTAKE HOLE ON HOUSING
- SPEED DISPLAY
- SPEED CONTROLLER

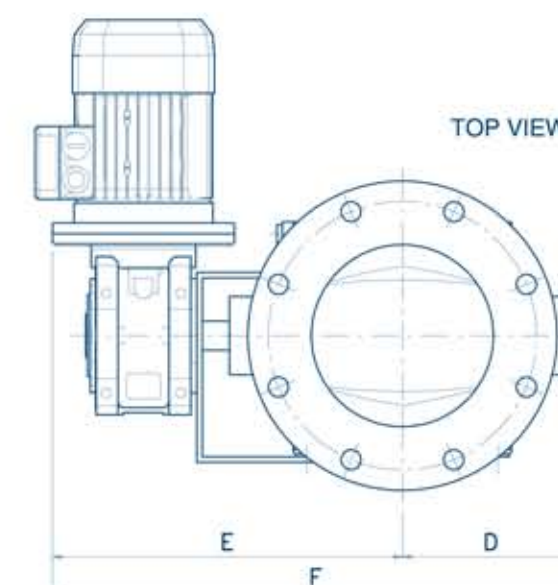
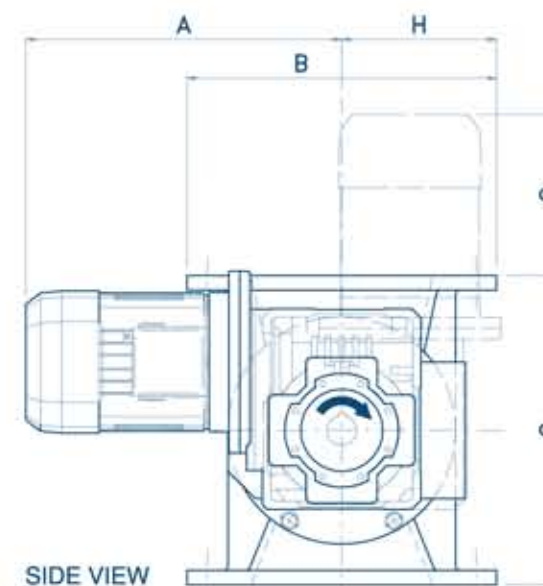
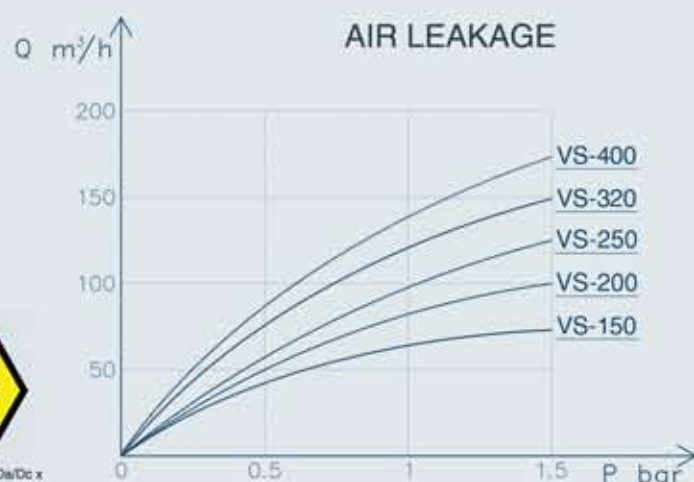

	A	B	C	D	E	F	G	H	L./Rev.	Rev./1' max	POWER	WEIGHT
150	400	∅250	260	158	325	545	180	31	2,2	30	Kw 0,18	Kg 60
200	400	∅340	340	195	385	580	180	75	4,5	30	Kw 0,55	Kg 95
250	400	∅395	400	210	400	610	180	75	8	30	Kw 0,75	Kg 115
320	450	∅445	500	225	420	645	180	87	16	30	Kw 1,10	Kg 175
400	450	∅500	580	240	440	680	180	87	37	30	Kw 1,10	Kg 215

FRONTAL VIEW

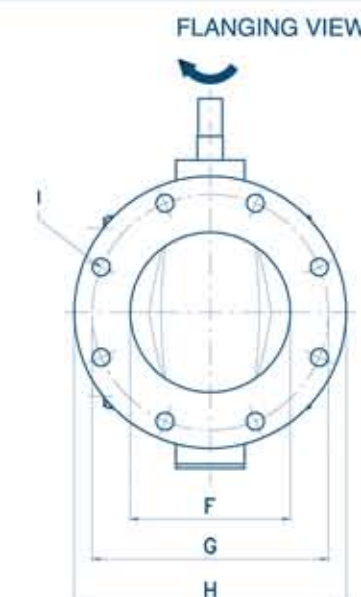
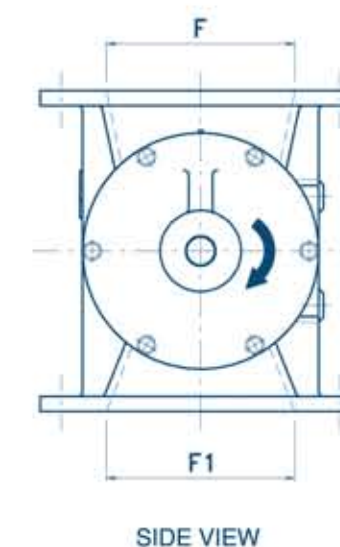
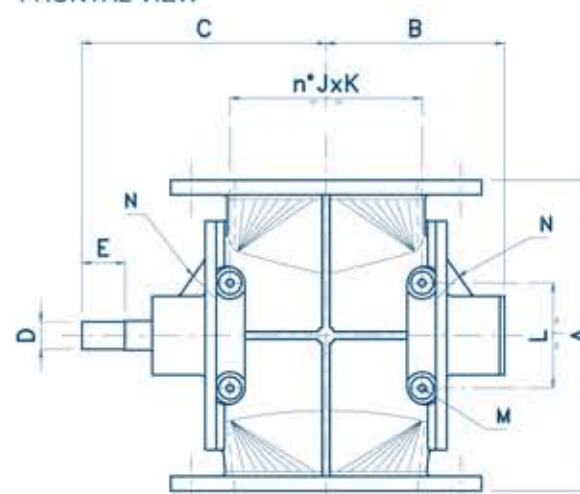

	A	B	C	D	E	F	F1	G	H	I	J	K	L	M	L./Rev.	N
150	260	152	235	∅25	70	∅135	∅135	∅210	∅250	8XM16	1	165	110	4XM10	2,2	1/8" GAS
200	340	190	267	∅30	47	∅200	∅200	∅295	∅340	8X∅22	1	210	115	4XM10	4,5	1/8" GAS
250	400	205	282	∅30	47	∅265	∅265	∅350	∅395	12X∅22	2	117,5	125	6XM10	8	1/8" GAS
320	500	221	304	∅35	53	∅326	∅326	∅400	∅445	12X∅22	2	132,5	175	6XM10	16	1/8" GAS
400	570	280	368	∅40	56	∅350	∅350	∅460	∅505	16X∅22	3	125	220	8XM10	37	1/4" GAS

BROCHURE



COMPLIANCE



II 1/30 IIC T135°C Da/De x

BLOW THROUGH ROTARY VALVES are designed to handle pneumatic conveying in dilute and dense phase for every industrial application such as food, plastic, rubber, chemical, pharmaceutical and mining. Thanks to COMAV'S TECHNOLOGY our valve is used for powders and fine products, assuring a perfect reliability and meeting a wide range of customer's requirements. The rectangular flange and a special disalignment allow a complete cell discharge without any breakage of the product



### APPLICATIONS

- POWDER
- FINE PRODUCTS
- VACUUM CONVEYING
- PNEUMATIC CONVEYING
- MOCA – EC1935/2004

### DESIGN

- FLANGING: RECTANGULAR
- SIZE: 200,250,320,400,480
- HOUSING: CAST IRON CASTING, SS316L CASTING
- ROTOR: WELDED CARBON STEEL OR SS304, SS316L
- DRIVE: CHAIN TRANSMISSION STANDARD VERSION OR DIRECT DRIVE. AVAILABLE IN BARE SHAFT VERSION. ALL OUR DRIVES CAN BE CONTROLLED BY INVERTER
- ROBUST&COMPACT DESIGN WITH MINIMAL ROTOR TOLERANCE

### FEATURES

- PRESSURE: 1,5 BAR
- TEMPERATURE: MAX 65 °C
- AIR LEAKAGE: SEE CHART
- INTEGRATED CASTING INNER HOPPER ( BETTER FILLING EFFICIENCY)
- 8 VANES OPEN ENDS ROTOR

### OPTIONALS

- DIFFERENT ROTORS FOR DIFFERENT PRODUCTS
- NICKEL COATING EC1935/2004
- HARD CHROMIUM PLATING
- VARIOUS POLISHING DEGREES
- HIGH TEMPERATURE CONFIGURATION
- FEEDING HOPPER COMPLETE WITH AIR INTAKES
- AIR BLOW-IN PURGE
- AIR INTAKE HOLE ON HOUSING
- SPEED DISPLAY
- SPEED CONTROLLER

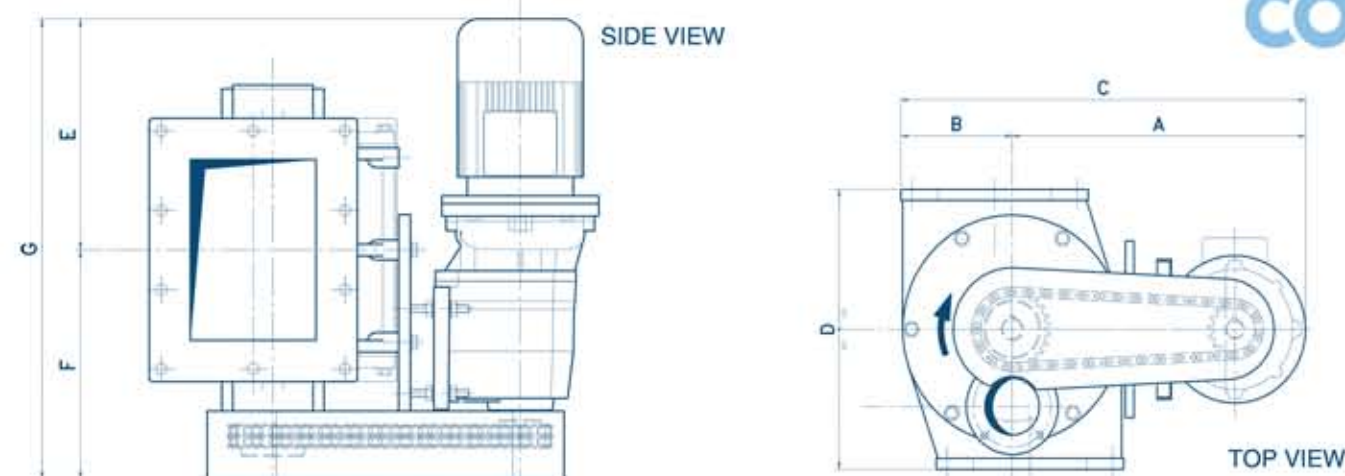
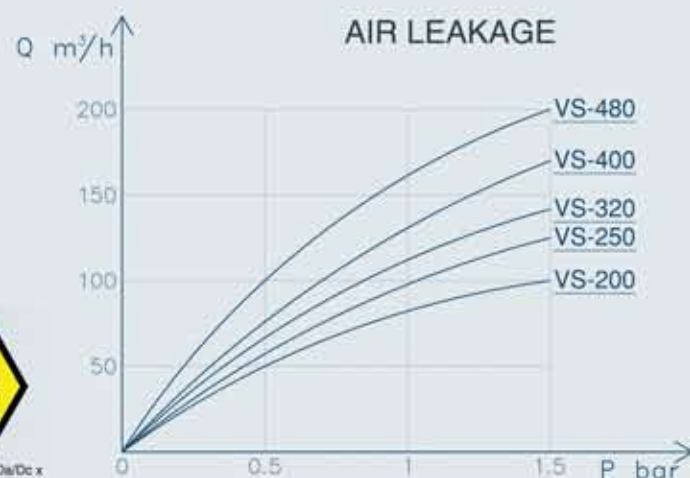

	A	B	C	D	E	F	G	L./Rev.	Rev./1' max	POWER	WEIGHT
200	360	132,5	492,5	320	235	280	515	4,5	30	Kw 0.37	Kg 90
250	410	157,5	567,5	380	255	295	550	8	30	Kw 0.55	Kg 127
320	455	192,5	647,5	450	274	321	595	16	30	Kw 0.75	Kg 196
400	555	237,5	792,5	570	285	380	665	37	30	Kw 1,10	Kg 345
480	635	282,5	917,5	660	255	425	680	65	30	Kw 1.50	Kg 585

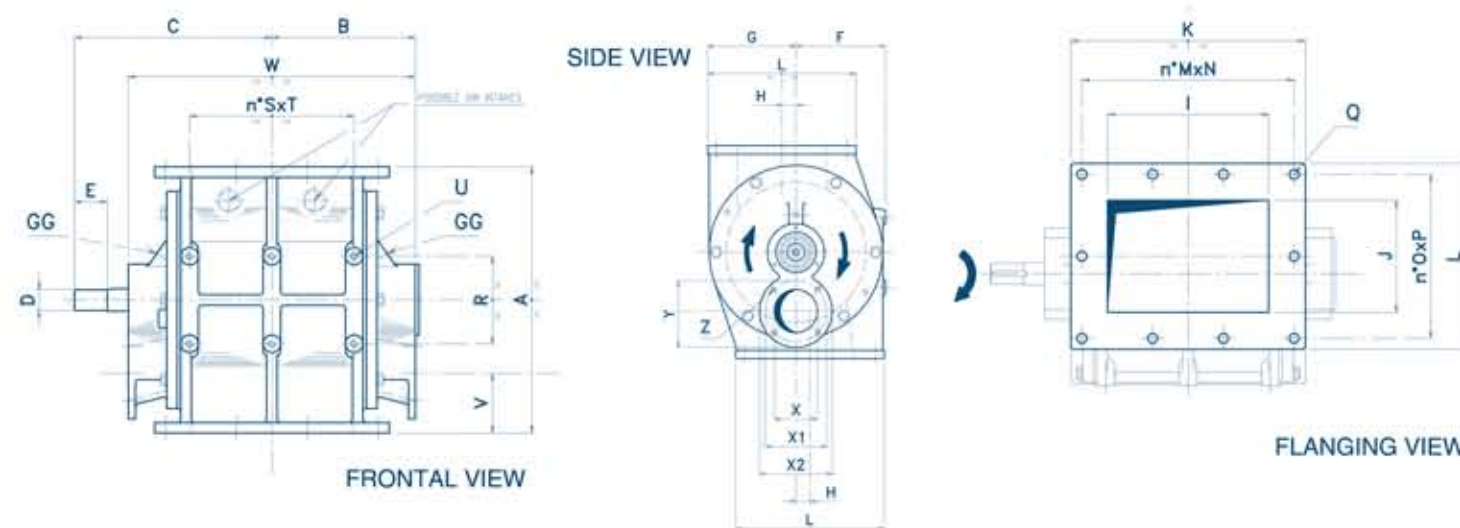

	A	B	C	D	E	F	G	H	I	J	K	L	M	N	O	P
200	320	190	267	ø30	47	130	132,5	20	200	140	285	225	3	86	2	99
250	380	205	282	ø30	47	160	157,5	25	230	160	335	265	3	101	2	117
320	450	221	304	ø35	53	195	192,5	40	260	200	365	305	3	111	2	136
400	570	280	368	ø40	56	240	237,5	55	370	260	475	365	4	110	2	165
480	660	315	405	ø52	65	305	282,5	70	444	300	570	425	4	132	2	191

	Q	R	S	T	U	V	W	X	Y	Z	X1	X2	L./Rev.	WEIGHT	GG
200	ø12	115	1	210	M10	70	380	ø60	100	M10	ø90	ø110	4,5	Kg 68	1/8" GAS
250	ø14	125	2	117,5	M10	85	410	ø77	117	M10	ø110	ø130	8	Kg 98	1/8" GAS
320	ø14	175	2	132,5	M10	100	442	ø99	148	M10	ø140	ø160	16	Kg 160	1/8" GAS
400	ø14	220	3	125	M10	131	560	ø129	189	M12	ø170	ø200	37	Kg 285	1/4" GAS
480	ø18	220	3	150	M10	147,5	630	ø156	108	M14	ø210	ø240	65	Kg 510	1/4" GAS

BROCHURE



COMPLIANCE



II 1/30 IIC T135°C Da/Dc x

# VSTF BLOW THROUGH ROTARY VALVE



BLOW THROUGH ROTARY VALVES are designed to handle pneumatic conveying in dilute and dense phase for every industrial application such as food, plastic, rubber, chemical, pharmaceutical and mining. Thanks to COMAV'S TECHNOLOGY our valve is used for powders and fine products, assuring a perfect reliability and meeting a wide range of customer's requirements. The round flange allows an easy connection to the conveying line and the equipment.



## APPLICATIONS

- POWDER
- FINE PRODUCTS
- VACUUM CONVEYING
- PNEUMATIC CONVEYING
- MOCA – EC1935/2004

## DESIGN

- FLANGING: ROUND UNI 2277-67 PN 10
- SIZE: DN150, DN200, DN250, DN300
- HOUSING: CAST IRON CASTING SS316L
- ROTOR: WELDED CARBON STEEL OR SS304, SS316L
- DRIVE: CHAIN TRANSMISSION STANDARD VERSION OR DIRECT DRIVE. AVAILABLE IN BARE SHAFT VERSION ALL OUR DRIVES CAN BE CONTROLLED BY INVERTER
- ROBUST&COMPACT DESIGN WITH MINIMAL ROTOR TOLERANCE

## FEATURES

- PRESSURE: 1,5 BAR
- TEMPERATURE: MAX 65 °C
- AIR LEAKAGE: SEE CHART
- INTEGRATED CASTING INNER HOPPER ( BETTER FILLING EFFICIENCY)
- 8 VANES OPEN ENDS ROTOR

## OPTIONALS

- DIFFERENT ROTORS FOR DIFFERENT PRODUCTS
- NICKEL COATING EC1935/2004
- HARD CHROMIUM PLATING
- VARIOUS POLISHING DEGREES
- HIGH TEMPERATURE CONFIGURATION
- FEEDING HOPPER COMPLETE WITH AIR INTAKES
- AIR BLOW-IN PURGE
- AIR INTAKE HOLE ON HOUSING
- SPEED DISPLAY
- SPEED CONTROLLER

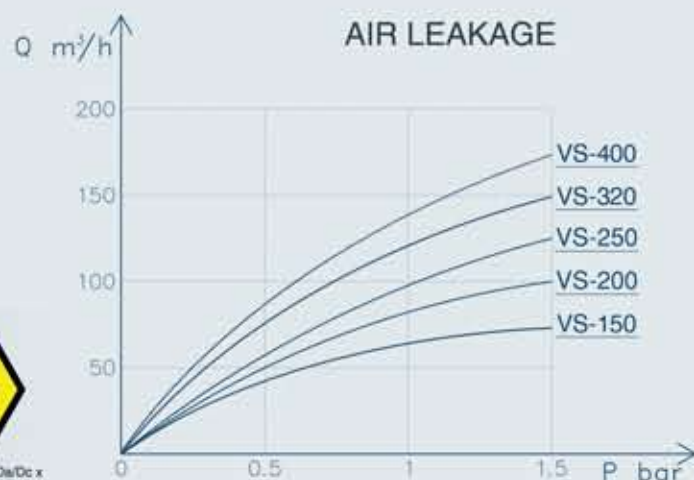

SIDE VIEW

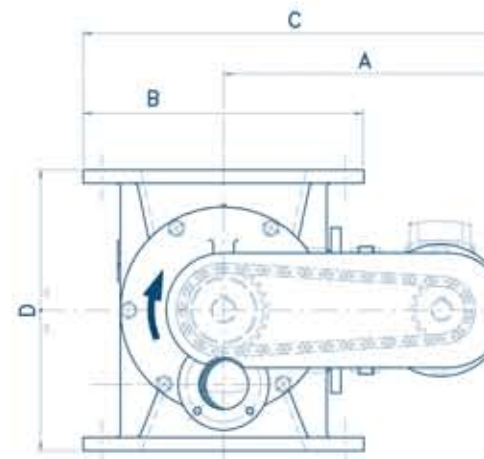

TOP VIEW

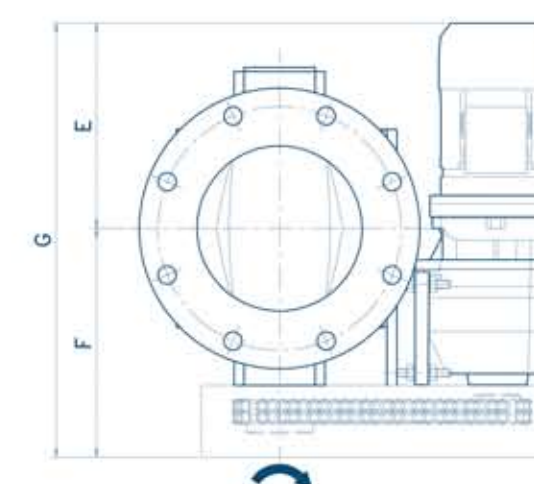

	A	B	C	D	E	F	G	L./Rev.	Rev./1' max	POWER	WEIGHT
150	305	ø250	430	260	245	265	480	2,2	30	Kw 0,25	Kg 60
200	360	ø340	500	340	250	280	530	4,5	30	Kw 0,55	Kg 90
250	410	ø395	607	400	255	295	550	8	30	Kw 0,55	Kg 127
320	455	ø445	667	500	275	320	595	16	30	Kw 0,75	Kg 195
400	500	ø500	720	580	295	335	625	37	30	Kw 1,10	Kg 245

FRONTAL VIEW

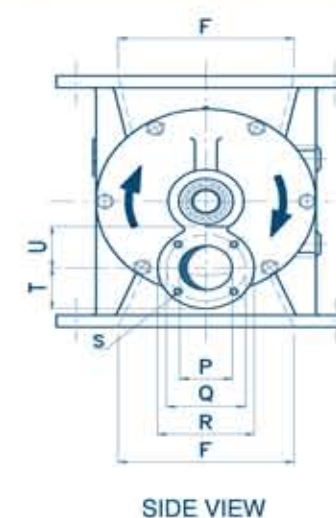
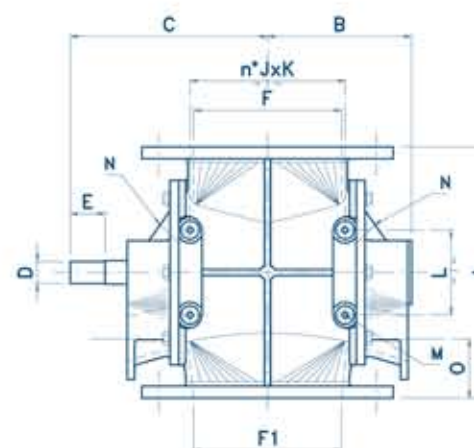

FLANGING VIEW

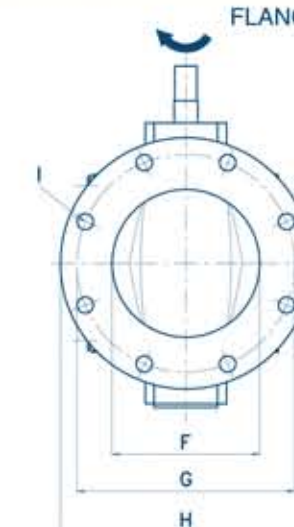

	A	B	C	D	E	F	F1	G	H	I	J	K
150	260	152	235	ø25	47	ø135	ø135	ø210	ø250	8XM16	1	165
200	340	190	267	ø35	47	ø200	ø200	ø295	ø340	8Xø22	1	210
250	400	205	282	ø35	47	ø265	ø265	ø350	ø395	12Xø22	2	117,5
320	500	220	305	ø35	53	ø326	ø326	ø400	ø445	12Xø22	2	132,5
400	580	235	325	ø35	53	ø390	ø390	ø450	ø495	12Xø22	2	147,5

	L	M	O	P	Q	R	S	T	U	L./Rev.	N
150	110	4XM10	45	ø47	ø80	ø100	M8	42	50	2,2	1/8" GAS
200	115	4XM10	80	ø60	ø90	ø110	M10	55	55	4,5	1/8" GAS
250	125	6XM10	95	ø77	ø110	ø130	M10	65	65	8	1/8" GAS
320	175	6XM10	125	ø99	ø140	ø160	M10	80	80	16	1/8" GAS
400	185	6XM10	155	ø120	ø170	ø190	M10	95	95	37	1/8" GAS

BROCHURE



COMPLIANCE



II 1/30 IIC T135°C Da/De x

VSFC ROTARY VALVE is designed to discharge containers holding powders and granules. Thanks to COMAV'S TECHNOLOGY can be used upon all hard applications, assuring an average discharge time of 50/60 minutes per 30" Container.

The valve capacity and its shape meet the main logistic companies needs.



## APPLICATIONS

- ON CHASSIS
- GENERAL PNEUMATIC CONVEYING
- POWDER
- GRANULE
- MOCA – EC1935/2004

## DESIGN

- FLANGING: RECTANGULAR
- SIZE: 320
- HOUSING: CAST IRON CASTING, SS304 OR SS316L CASTING
- ROTOR: WELDED CARBON STEEL OR SS304, SS316L
- DRIVE: DIRECT DRIVE, CHAIN TRANSMISSION, ELECTRIC OR HYDRAULIC MOTOR AVAILABLE IN BARE SHAFT VERSION.
- ROBUST & COMPACT DESIGN WITH MINIMAL ROTOR TOLERANCE

## FEATURES

- PRESSURE: -0,5 BAR, +2 BAR
- MAX PRESSURE FOR HYDRAULIC MOTOR: 70 BAR
- QUANTITY OF REQUEST OIL : 50 KG/MIN (IN CASE OF HYDRAULIC MOTOR)
- TEMPERATURE: MAX 65 °C
- ROTATION SPEED: 42 RPM MAX
- INTEGRATED CASTING INNER HOPPER ( BETTER FILLING EFFICIENCY)
- OPEN ENDS ROTOR UP TO 10 VANES

## OPTIONALS

- DIFFERENT ROTORS FOR DIFFERENT PRODUCTS
- NICKEL COATING EC1935/2004
- HARD CHROMIUM PLATING
- VARIOUS POLISHING DEGREES
- HIGH TEMPERATURE CONFIGURATION
- FEEDING SHOE
- FEEDING HOPPER COMPLETE WITH FLAP VALVE
- AIR BLOW-IN PURGE
- AIR INTAKE HOLE ON HOUSING
- SPEED DISPLAY
- SPEED CONTROLLER



FRONTAL VIEW

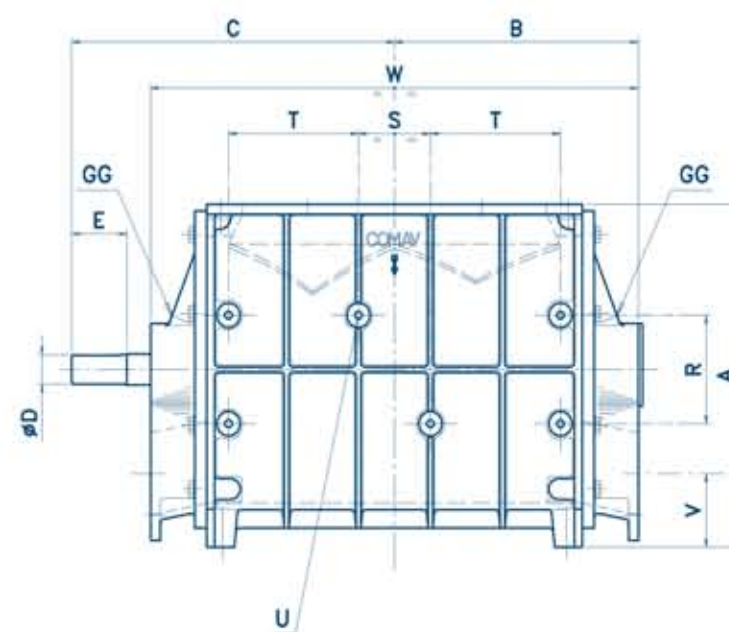

SIDE VIEW

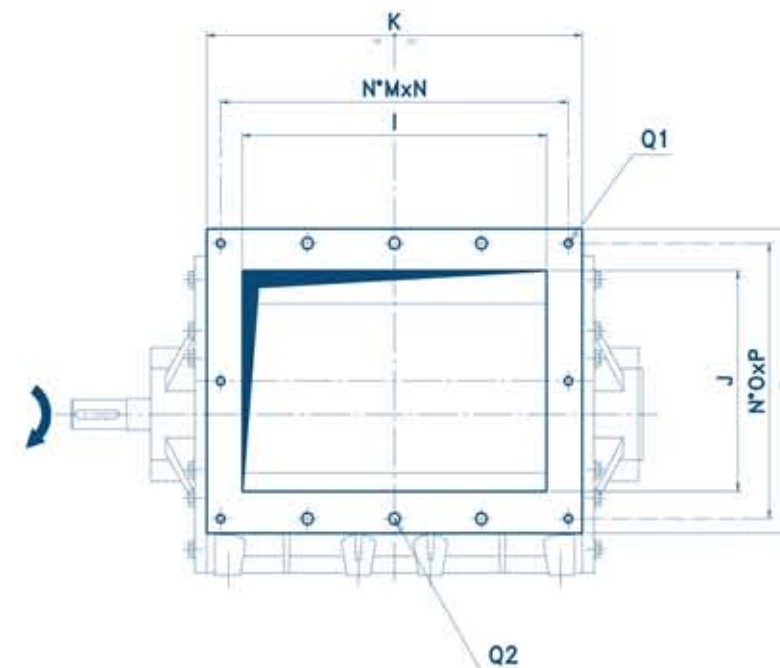
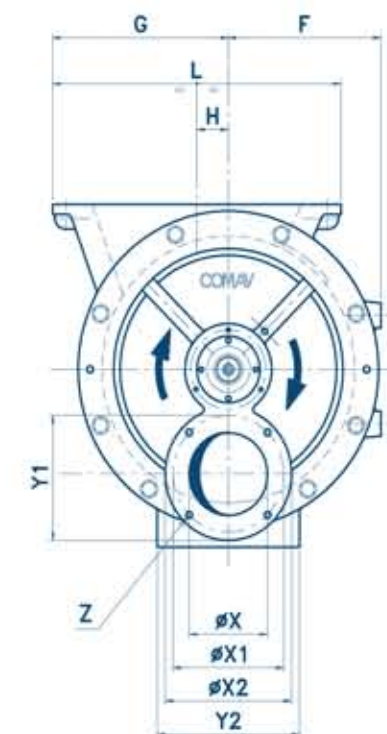

FLANGING VIEW

	A	B	C	D	E	F	G	H	I	J	K	L	M	N	O	P	Q1	Q2
320	411	309	409	ø35	70	193	222,5	40	385	265	475	365	4	110	2	165	M12	ø14
	R	S	T	U	V	W	X	X1	X2	Y1	Y2	Z	L/Rev.	WEIGHT	GG			
320	130	91	164,5	M10	88	617	ø99	ø140	ø160	150	180	M10	29	Kg 170	1/8" GAS			

BROCHURE



COMPLIANCE



# 1/30 IIC T135°C Da/De x



# ROTORS

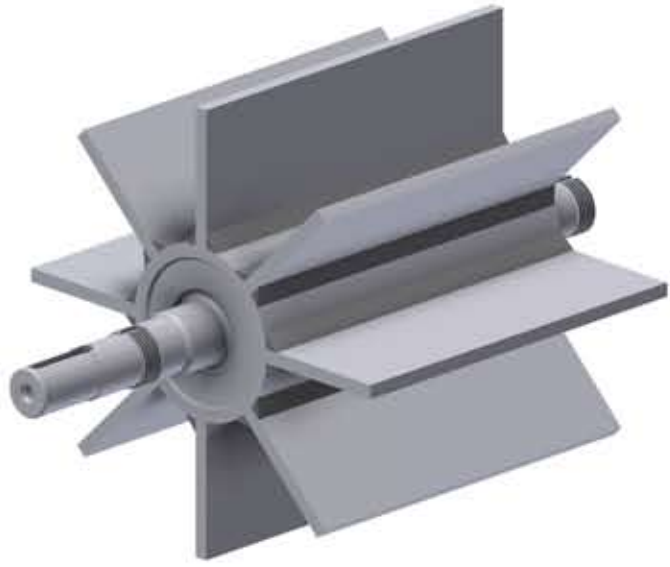

**ROTOR A**  
STANDARD

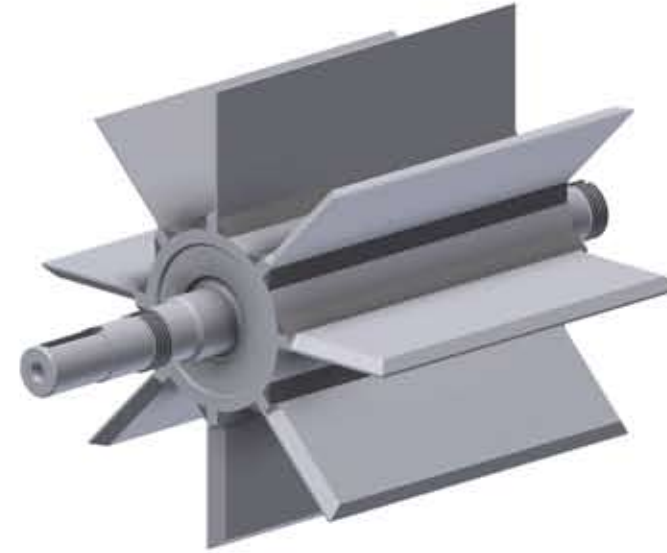

**ROTOR C**  
TOTALLY BEVELLED

**ROTOR B**  
UPPER BEVELLED ON HEAD

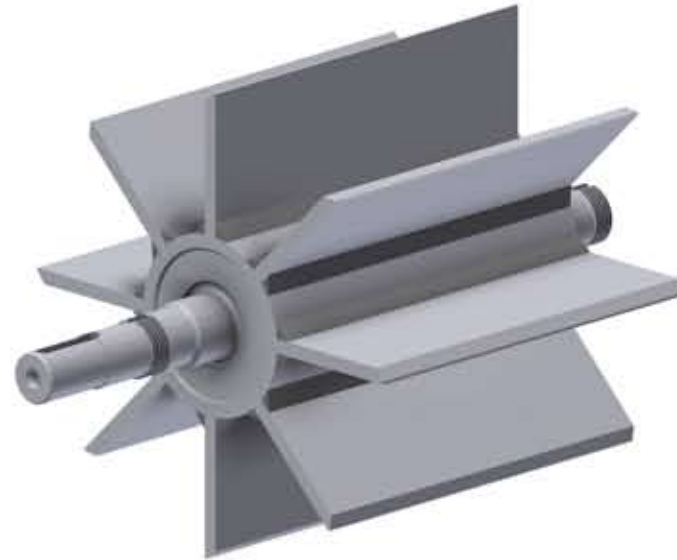

**ROTOR D**  
THIN TIPS

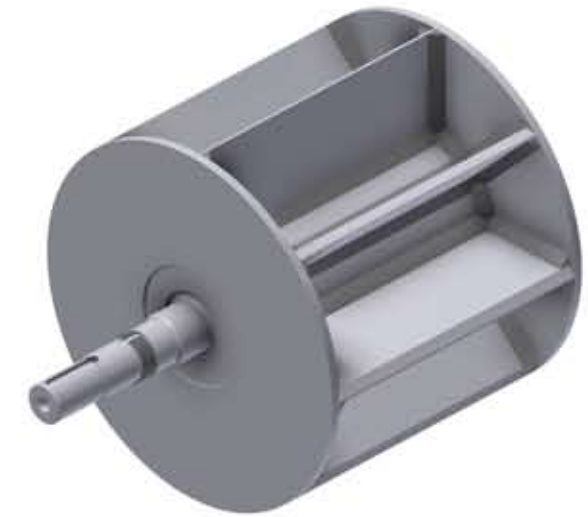

**CLOSED  
ROTOR**



**ROTOR D**  
TOUGH TIPS

**PARTIAL  
ROTOR**



**ROTOR E**  
HARMONIC SS TIPS



# FEEDING SHOE

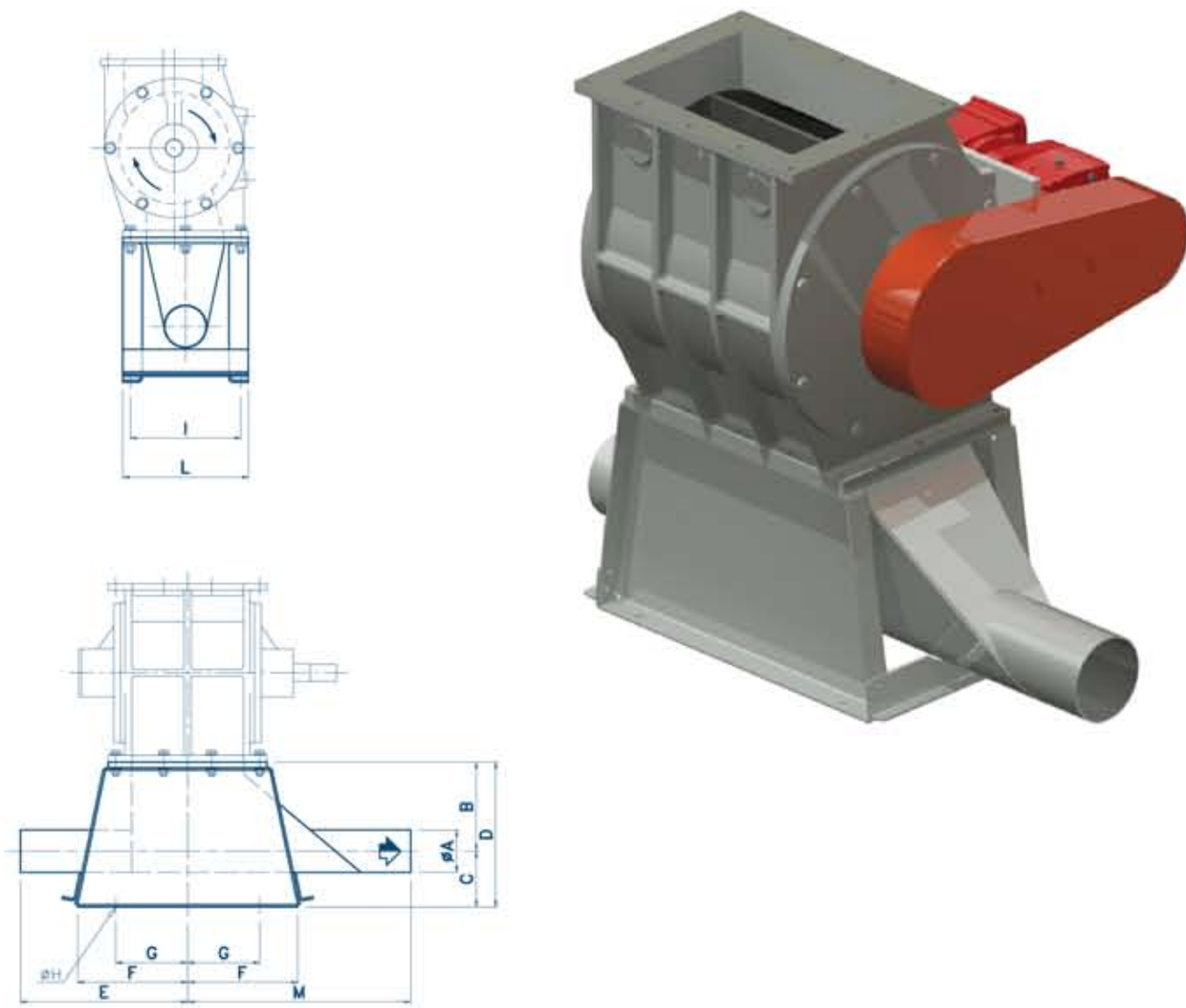

VSD	ØA		B	C	D	E	F	G	ØH	I	L	M
	MIN	MAX										
200	ø60,3x2	ø88,9x3	160	100	260	300	198	129	4xø12	198	225	400
250	ø60,3x2	ø101,6x3	160	100	260	370	223	152	4xø12	234	265	430
320	ø88,9x2	ø154,0x3	200	120	320	350	238	167	4xø14	272	305	500
400	ø101,6x2	ø154,0x3	250	125	375	425	293	220	4xø14	330	365	625
480	ø154,0x3	ø219,1x3	300	175	475	500	315	290	4xø18	382	425	700

# FEEDING HOPPER

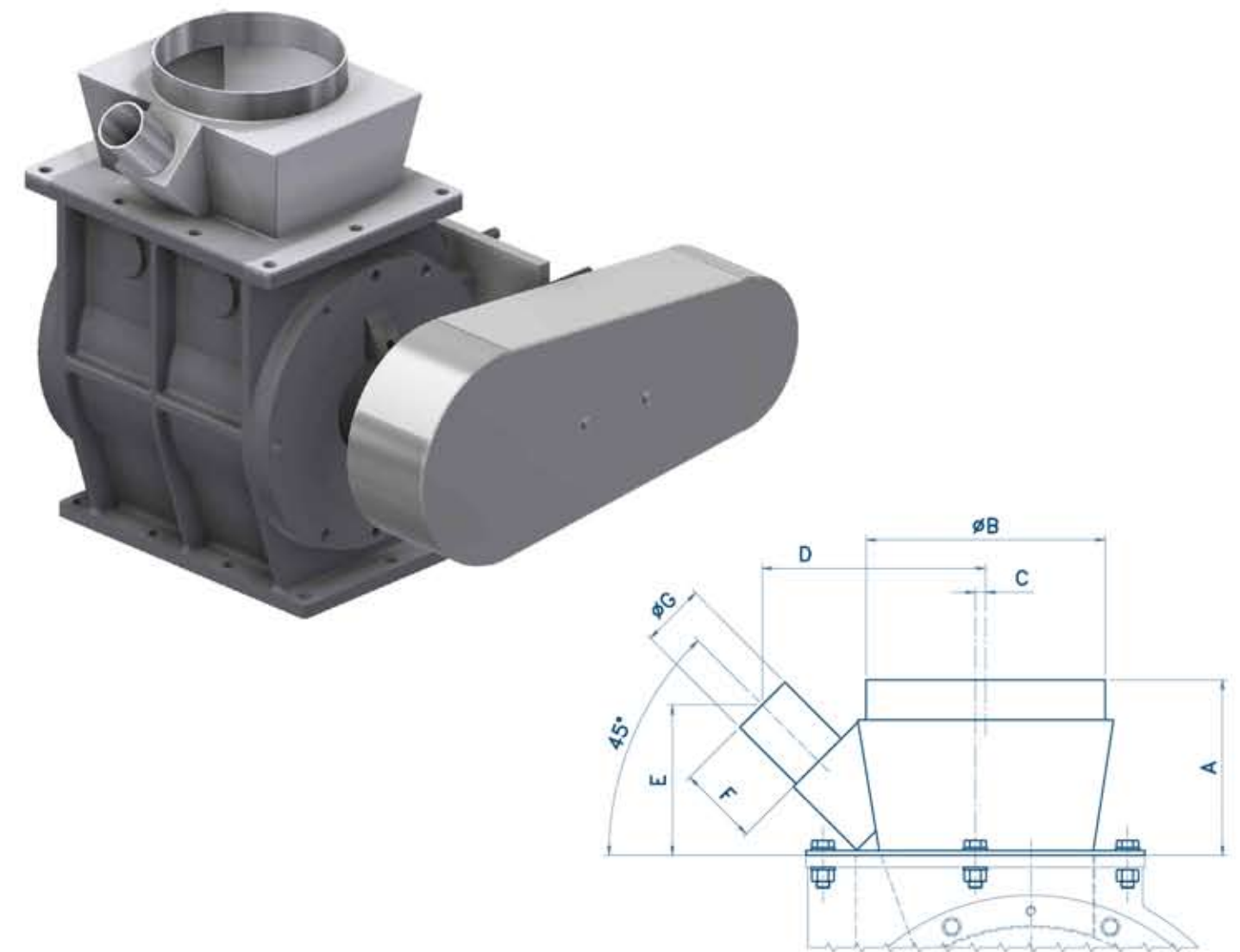

VS	A	ØB	C	D	E	F	ØG
200	200	ø150	0	180	165	80	ø60
200	200	ø200	0	190	180	80	ø60
250	200	ø200	0	195	175	80	ø60
320	200	ø200	0	205	165	80	ø60
320	200	ø250	0	220	175	80	ø60
400	220	ø250	0	250	195	100	ø80
400	220	ø300	0	265	205	100	ø80
480	220	ø250	13	270	175	100	ø80
480	220	ø300	13	280	190	100	ø80

# DOSING HOPPER

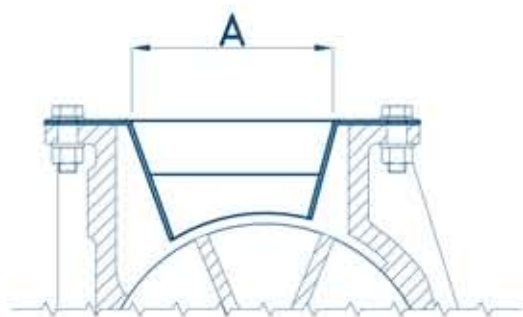
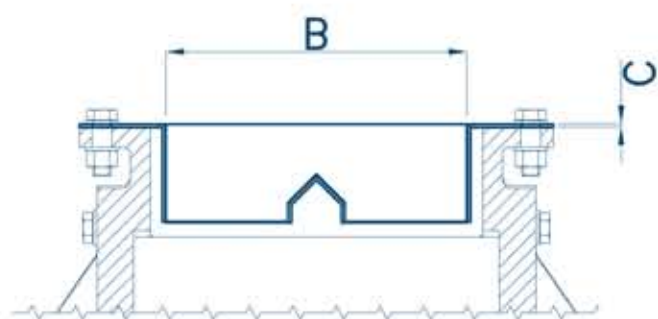
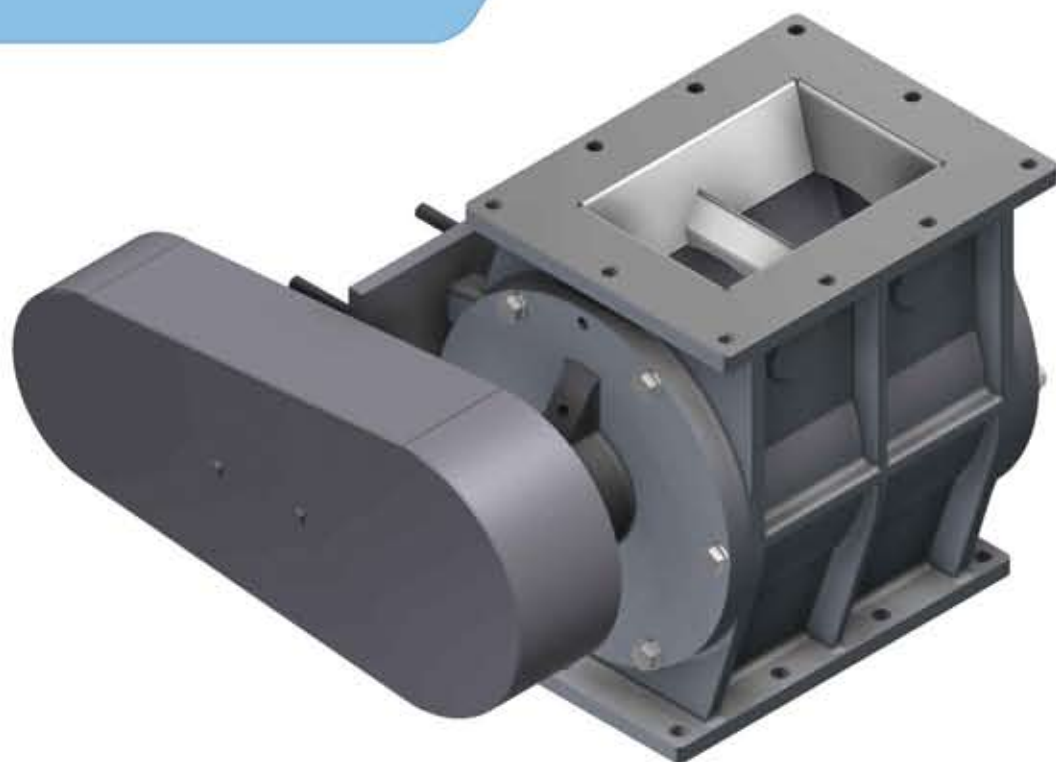

VS	A	B	C
200	125	185	2
250	145	215	2
320	185	245	2
400	245	355	2,5
480	285	430	2,5

# FEEDING HOPPER

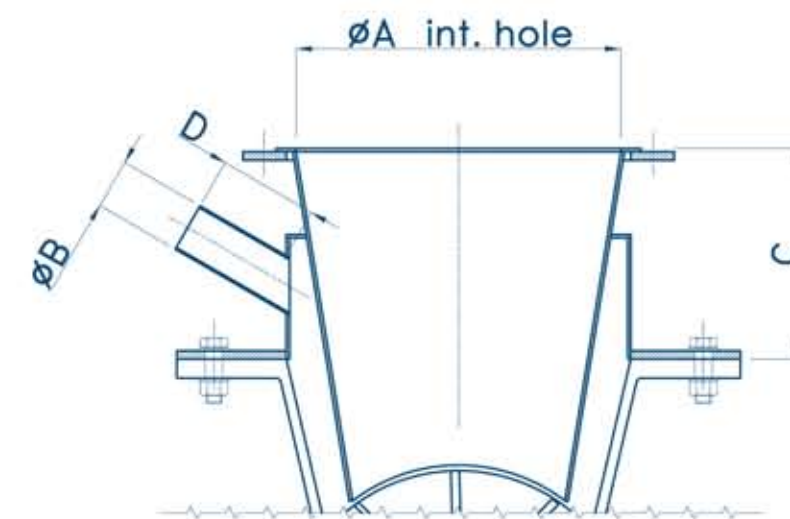

VST	A	B	C	D
150	ø106	ø33,7	90	60
200	ø200	ø33,7	170	60
250	ø269	ø40,0	170	60
320	ø296	ø60,0	185	60
400	ø326	ø80,0	220	80

# DOSING HOPPER

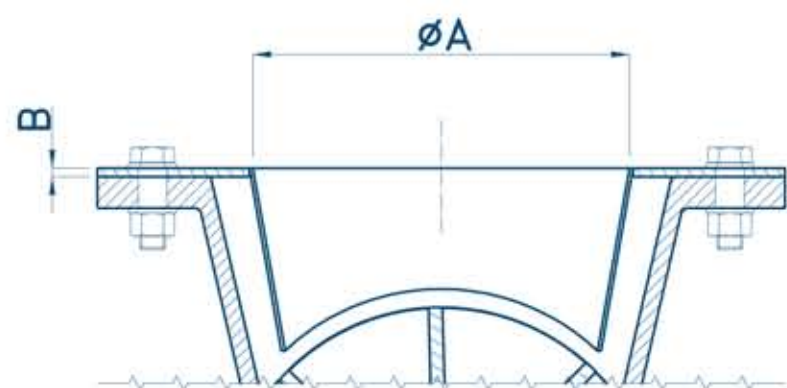

VSD	A	B
200	ø197	3
250	ø262	3

# ROTATING SENSOR

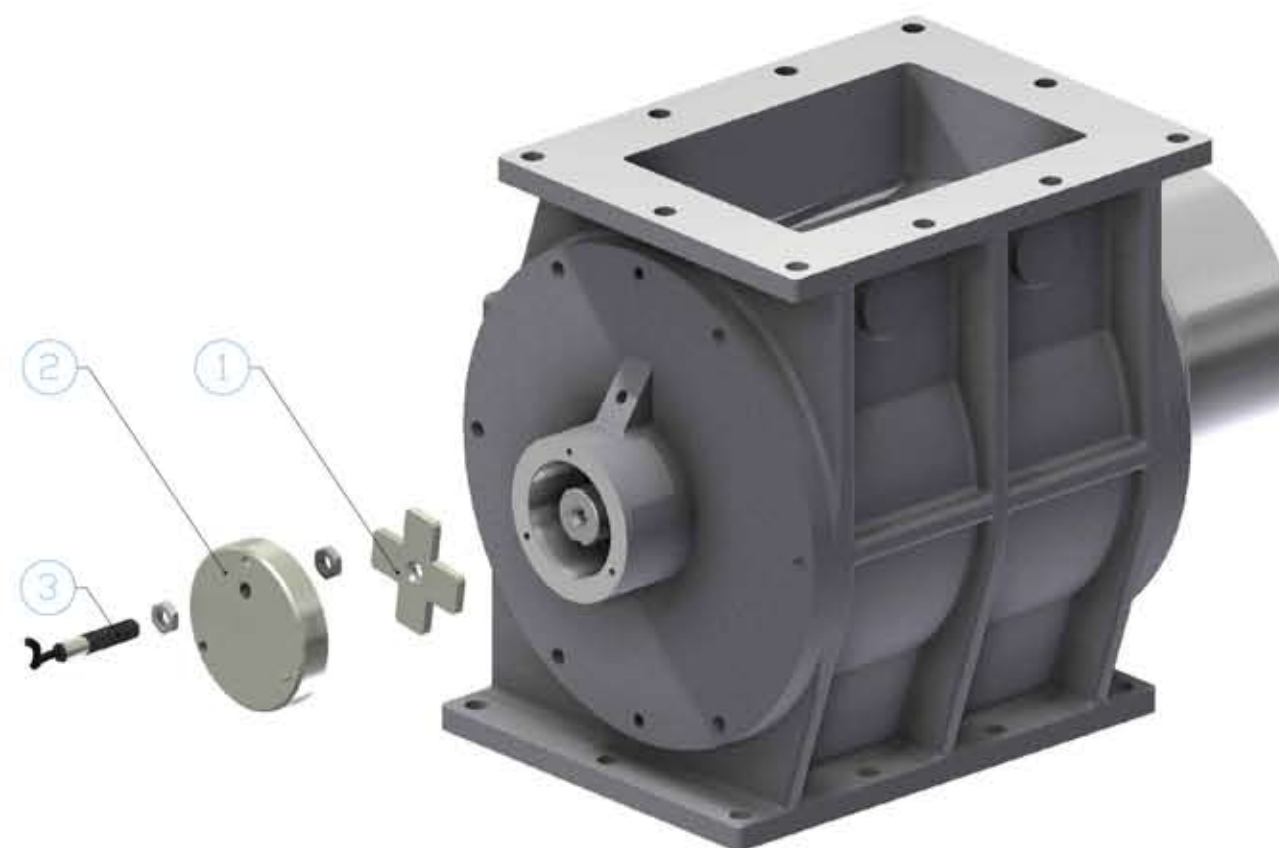

POS	ITEM
1	SENSOR CAM
2	SENSOR COVER
3	SENSOR

AVAILABLE FOR ALL MODELS

# AIR BLOWING-IN

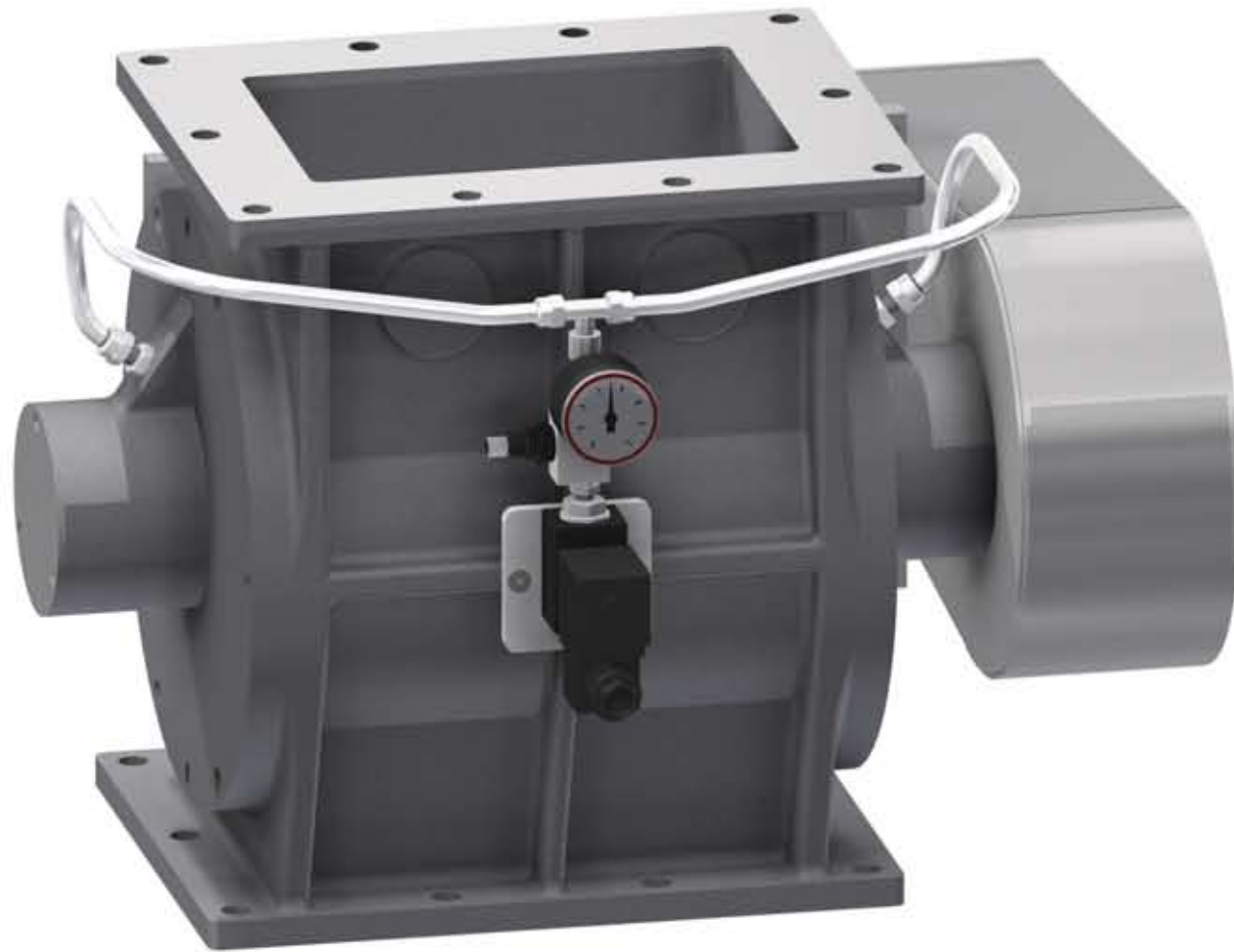

VS	200	250	320	400	480
	1/8" GAS	1/8" GAS	1/8" GAS	1/4" GAS	1/4" GAS



**HIGH TEMPERATURE**  
WITH SPECIAL TOLERANCE  
OR EXTERNAL BALL-BEARINGS  
VERSION

**DETACHABLE**  
AVAILABLE FOR  
ALL MODELS



**VALVE MOUNTED  
ON PLATFORM**



**VALVE  
MOUNTED  
ON TROLLEY**



SINGLE PIPE STATIC DIVERTER VALVES are designed to divert the product from one way to two ways and vice versa

DTS DIVERTER VALVES are used for general pneumatic conveying up to 1 bar of convey pressure with all kinds of product such as powders and granules.



### APPLICATIONS

- PNEUMATIC CONVEYING
- DISCHARGE
- POWDER
- GRANULE
- MOCA – EC1935/2004

### DESIGN

- SIZE: FROM DN80, TO DN150
- BODY AND COVER: CASTING ALUMINIUM
- ROTOR: CASTING ALUMINIUM
- INNER PIPE: ALUMINIUM OR LINING ROTOR MADE OF SS304 / SS316L
- CONTROL: ACTUATOR, ELECTRICAL OR MANUAL

### FEATURES

- PRESSURE: 1 BAR
- TEMPERATURE: MAX 100 °C
- ANGLE: 30°
- SEAL CONFIGURATION: STATIC
- SPACE SAVING INSTALLATION

### OPTIONALS

- ACTUATOR ON COVER SIDE
- NICKEL COATING EC1935/2004
- SPECIAL EXECUTION FOR ABRASIVE PRODUCT
- SPECIAL PIPE ON REQUEST FOR SPECIAL APPLICATION
- SPECIAL EXECUTION FOR DIRECT FITTING AT PIPING
- HIGH TEMPERATURE VERSION
- ADAPTOR KIT

### AIR CONSUMPTION

DT	Actuator	N. Lt.
80 - 150	UT35	3,40

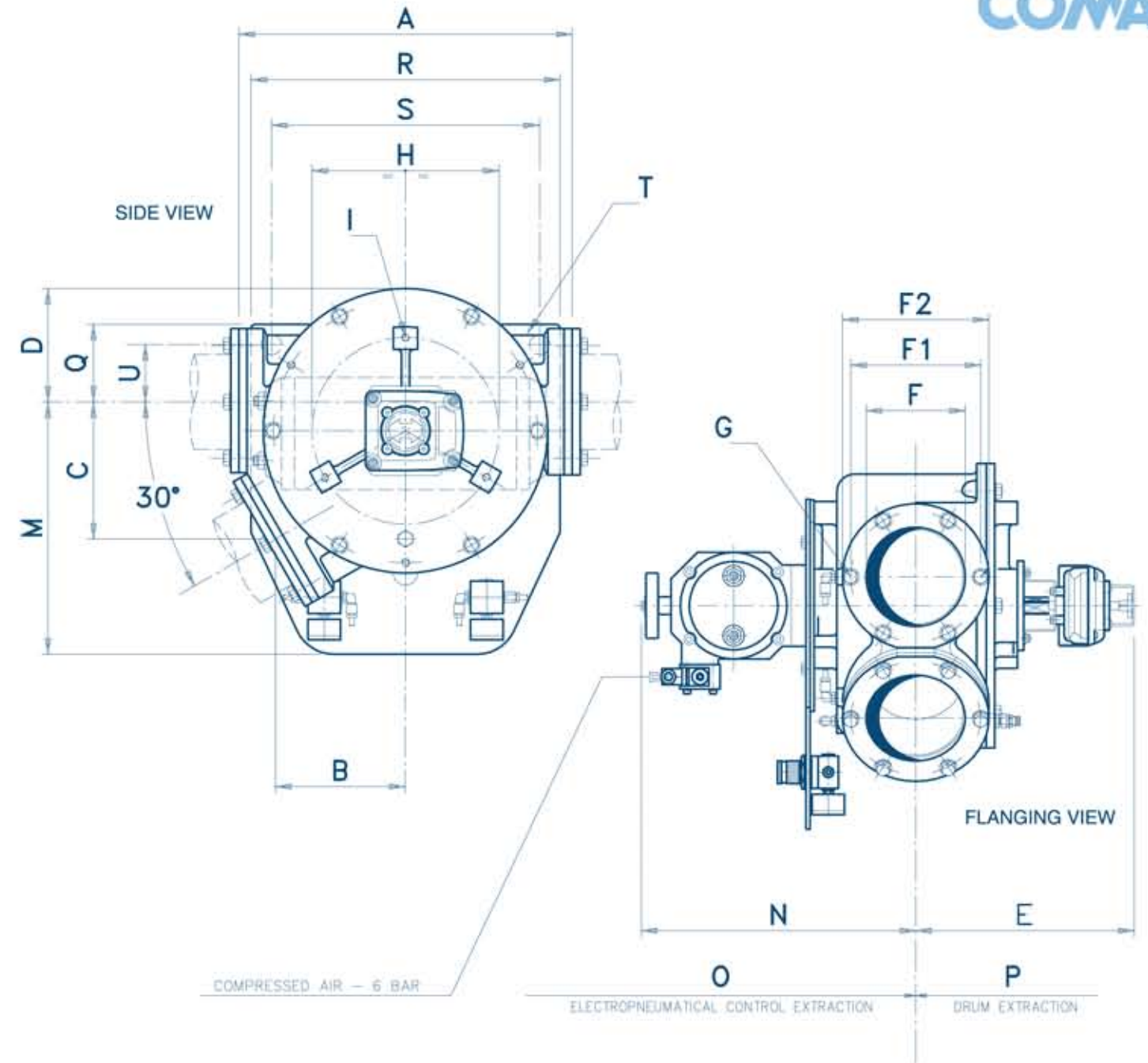

	A	B	C	D	E	ALL	F	F1	F2	G	H	I
80	350	138	137	105	244	ø77	ø76	ø120	ø140	4xM10	ø210	M10
100	390	153	155	125	256	ø99	ø97,6	ø140	ø160	6xM10	ø210	M10
120	410	160	169	140	269	ø117	ø117	ø160	ø180	6xM10	ø230	M10
150	510	200	206	168	285	ø146	ø146	ø190	ø215	6xM10	ø230	M10

	M	N	O	P	Q	R	S	T	U	WEIGHT
80	302	317	417	400	105	380	330	2 x ø25	80	Kg 20,5
100	306	329	429	435	100	380	330	2 x ø25	75	Kg 26,5
120	311	338	438	460	96	380	330	2 x ø25	71	Kg 34,0
150	318	354	454	510	89	380	330	2 x ø25	64	Kg 52,0

BROCHURE



COMPLIANCE



# 1/30 IIC T130°C Da/De x

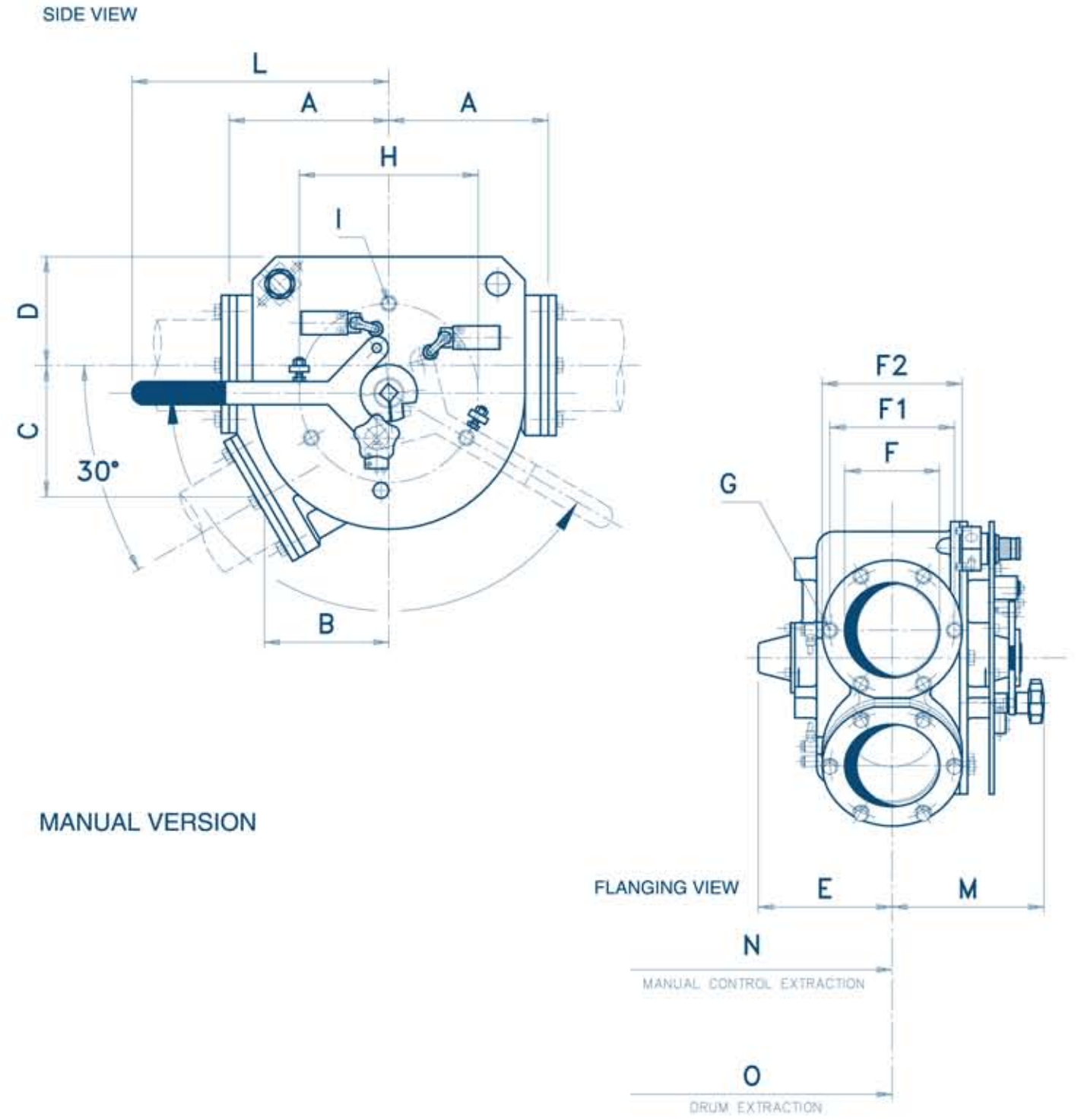
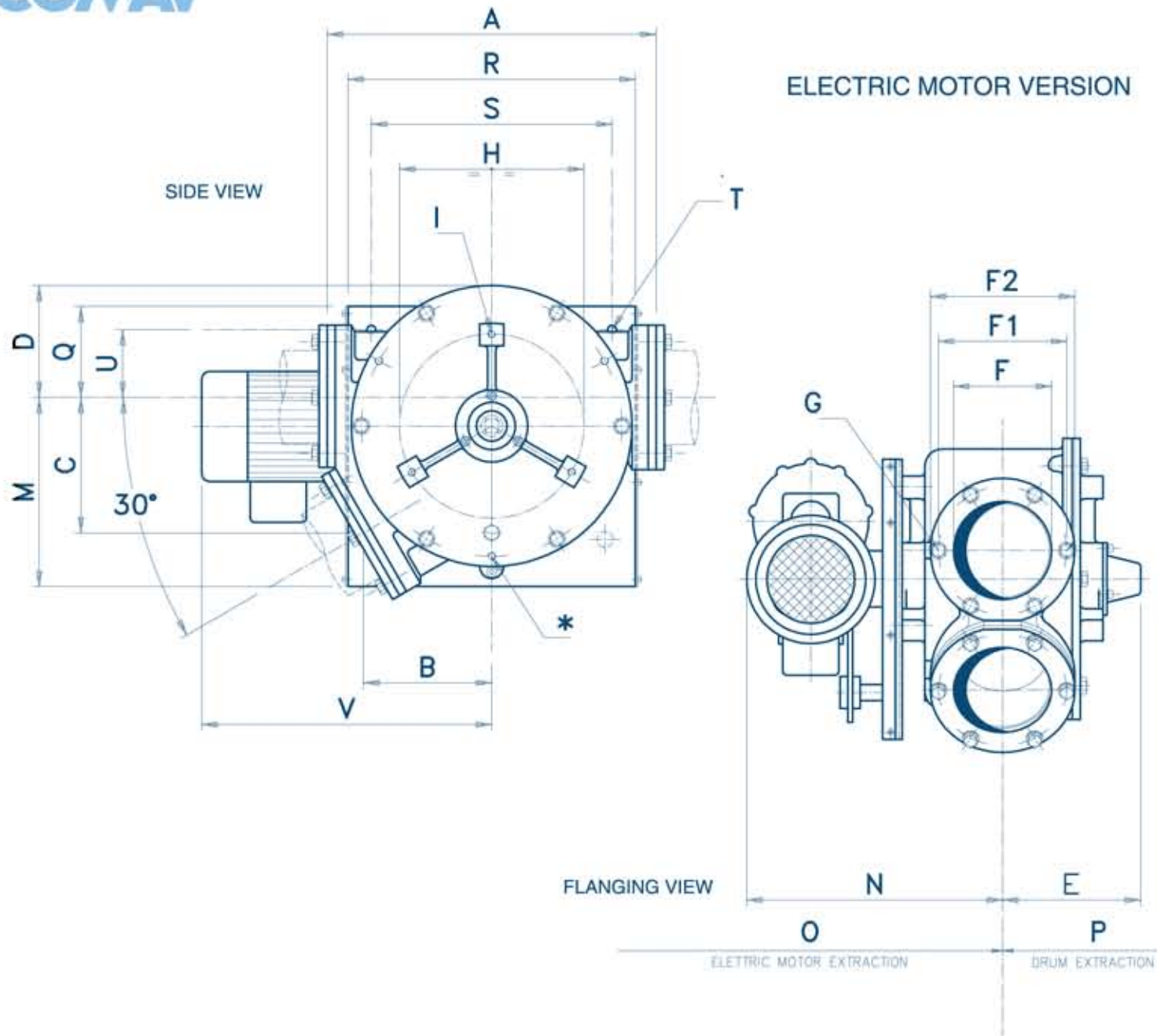

	A	B	C	D	E	ALL	F	F1	F2	G	H	I
						INOX	INOX					
80	350	138	137	109	152	ø77	ø76	ø120	ø140	4xM10	ø210	M10
100	390	153	155	125	165	ø99	ø97,6	ø140	ø160	6xM10	ø210	M10
120	410	160	169	140	175	ø117	ø117	ø160	ø180	6xM10	ø230	M10
150	510	200	206	168	190	ø146	ø146	ø190	ø215	6xM10	ø230	M10

	M	N	O	P	Q	R	S	T	U	V	KW
80	240	298	398	400	125	300	240	2 x ø11	30	336	0,18
100	240	310	410	435	120	300	240	2 x ø11	30	336	0,18
120	255	340	430	460	145	364	-	-	-	313	0,37
150	230	355	455	510	105	360	300	2 x ø11	30	336	0,37

	A	B	C	D	E	ALL	F	F1	F2	G	H	I	L	M	N	O
						INOX	INOX									
80	175	138	137	109	152	ø77	ø76	ø120	ø140	4xM10	ø210	M10	300	180	270	400
100	195	153	155	125	165	ø99	ø97,6	ø140	ø160	6xM10	ø210	M10	300	190	280	435
120	205	160	169	140	175	ø117	ø117	ø160	ø180	6xM10	ø230	M10	330	200	290	460
150	255	200	206	168	190	ø146	ø146	ø190	ø215	6xM10	ø230	M10	330	215	305	510

SINGLE PIPE PRESSURIZED DIVERTER VALVES are designed to divert the product from one way to two ways and vice versa

DTP DIVERTER VALVES are used for pneumatic conveying also in dense phase up to 4 bar of convey pressure thanks to a pressure control device. It is suitable for every kind of product such as powders and granules.



### APPLICATIONS

- DILUTE AND DENSE PHASE
- DISCHARGE
- POWDER
- GRANULE
- MOCA – EC1935/2004

### DESIGN

- SIZE: FROM DN80, TO DN260
- BODY AND COVER: CASTING ALUMINIUM
- ROTOR: CASTING ALUMINIUM
- INNER PIPE: ALUMINIUM OR LINING ROTOR MADE OF SS304 / SS316L
- CONTROL: ACTUATOR, ELECTRICAL OR MANUAL

### FEATURES

- PRESSURE: 4 BAR
- TEMPERATURE: MAX 100 °C
- ANGLE: 30°
- SEAL CONFIGURATION: PRESSURIZED
- SPACE SAVING INSTALLATION

### OPTIONALS

- ACTUATOR ON COVER SIDE
- NICKEL COATING EC1935/2004
- SPECIAL EXECUTION FOR ABRASIVE PRODUCT
- SPECIAL PIPE ON REQUEST FOR SPECIAL APPLICATION
- SPECIAL EXECUTION FOR DIRECT FITTING AT PIPING
- HIGH TEMPERATURE VERSION
- ADAPTOR KIT

### AIR CONSUMPTION

DT	Actuator	N. Lt.
80 - 150	UT35	3,40
180 - 260	UT50	9,50

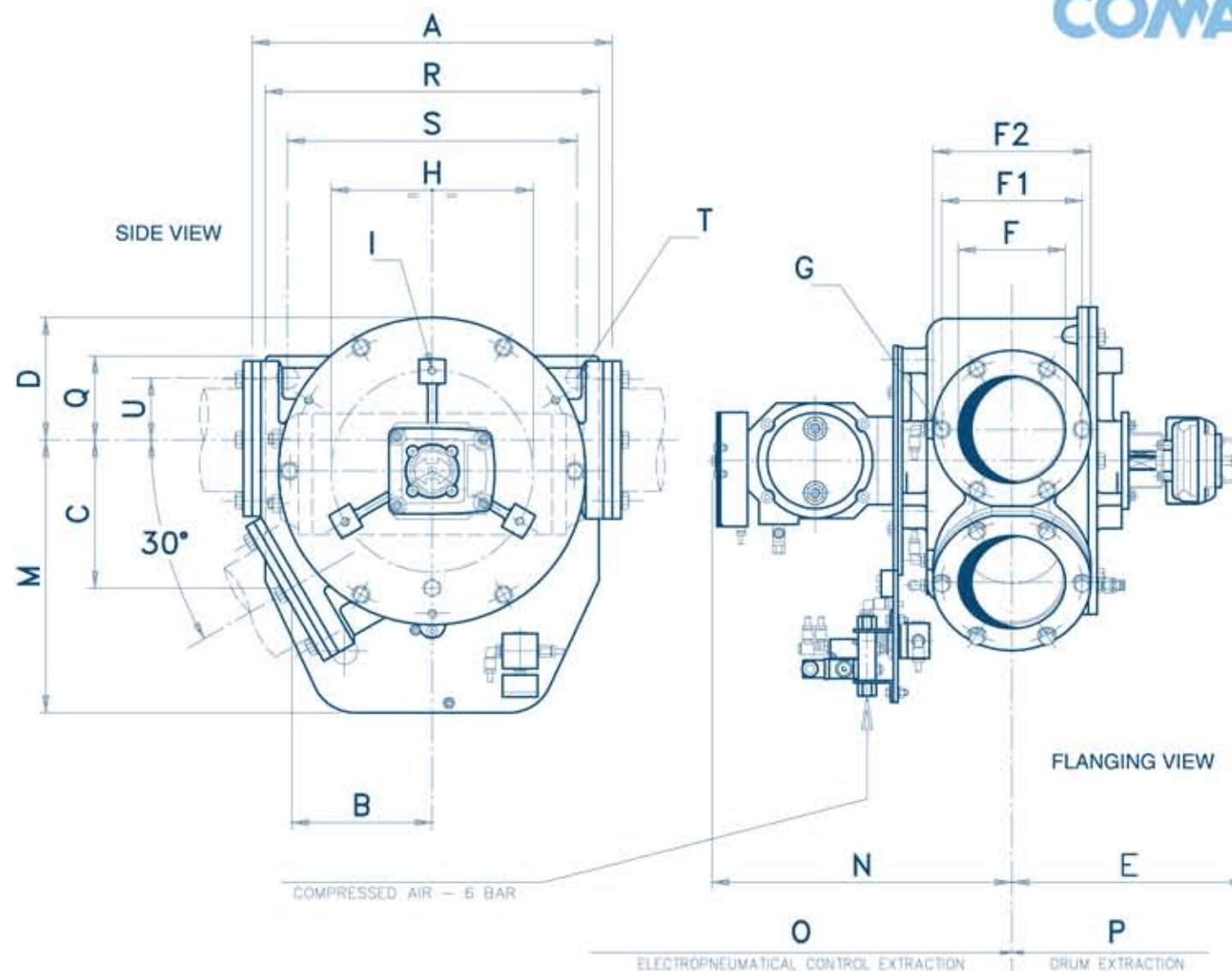

	A	B	C	D	E	ALL	F	F1	F2	G	H	I
80	350	138	137	105	244	ø77	ø76	ø120	ø140	4xM10	ø210	M10
100	390	153	155	125	256	ø99	ø97,6	ø140	ø160	6xM10	ø210	M10
120	410	160	169	140	269	ø117	ø117	ø160	ø180	6xM10	ø230	M10
150	510	200	206	168	285	ø146	ø146	ø190	ø215	6xM10	ø230	M10
180	570	222	235	198	305	ø176	ø176	ø220	ø245	6xM10	ø230	M10
220	674	263	280	231	320	ø215	ø215	ø265	ø290	6xM10	ø400	M10
260	754	293	316	262	340	ø255	ø255	ø305	ø330	6xM10	ø400	M10

	M	N	O	P	Q	R	S	T	U	WEIGHT
80	302	317	417	400	105	380	330	2 x ø25	80	Kg 20,5
100	306	329	429	435	100	380	330	2 x ø25	75	Kg 26,5
120	311	338	438	460	96	380	330	2 x ø25	71	Kg 34,0
150	318	354	454	510	89	380	330	2 x ø25	64	Kg 52,0
180	325	425	524	565	82	380	330	2 x ø25	57	Kg 70,5
220	445	441	539	625	186	490	440	2 x ø25	161	Kg 105
260	454	460	559	685	177	490	440	2 x ø25	152	Kg 170

BROCHURE



COMPLIANCE



II 1/30 IIC T130°C Da/De x



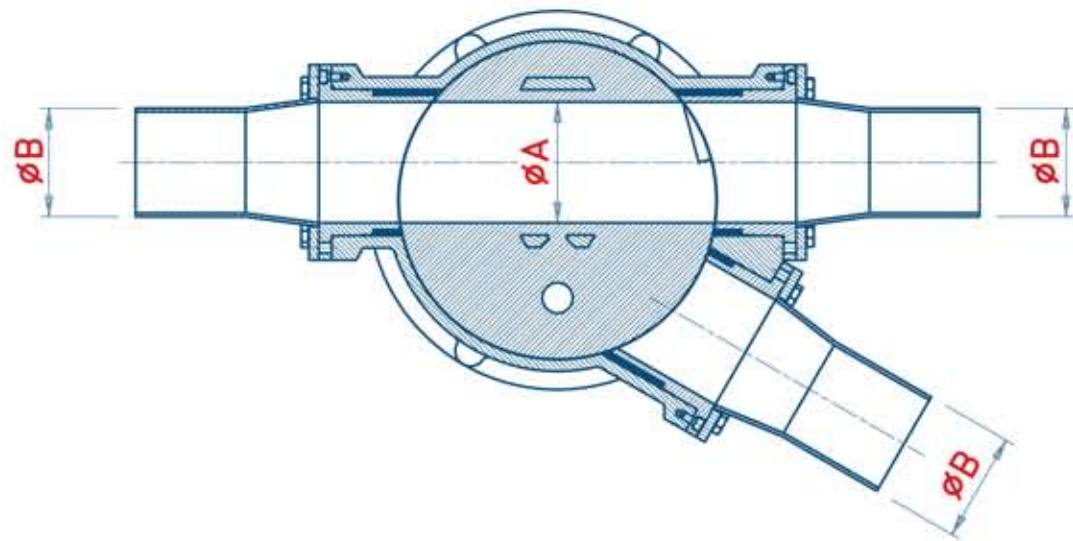

DT	80		100		120		150		180		220		260	
	AL	SS	AL	SS	AL	SS	AL	SS	AL	SS	AL	SS	AL	SS
ØA	77	76	99	97,6	117	117	146	146	176	176	215	-	255	255
ØB	60,3		88,9		114,3		114,3							
ØB EXT.	76,1		114,3		139,7		154							
	88,9				168,3									

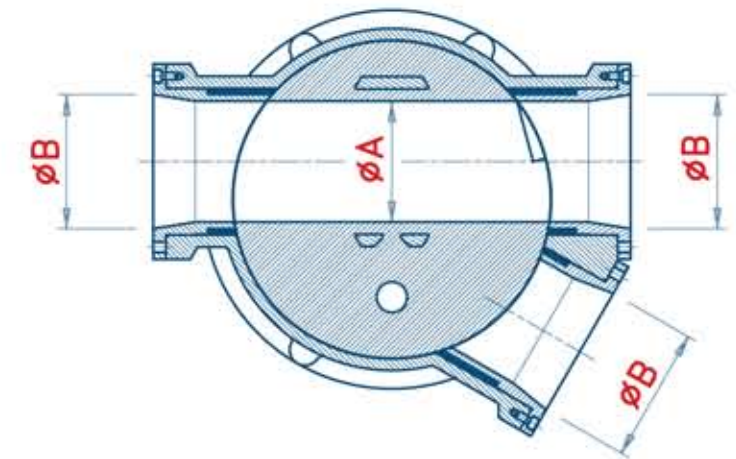

DT	80		100		120		150		180		220		260	
	AL	SS	AL	SS	AL	SS	AL	SS	AL	SS	AL	SS	AL	SS
ØA	77	76	99	97,6	117	117	146	146	176	176	215	-	255	255
	80	83	100,8	99	125	120	150	150	187	187	-	-	267	260,3
ØB	81,1	84,3	105	102,3		123								
ØB EXT.	82,9	84,9	110	105		125								
	83			110		127								
	84,3													
	84,9													

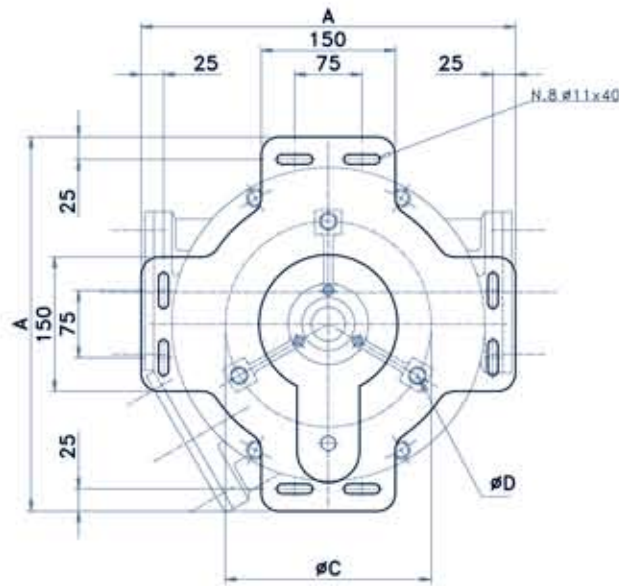

DTS/DTP	80	100	120	150	180	220	260
A	418	418	418	560	560	720	720
C	210	210	230	230	230	400	400
D	M10	M10	M10	M10	M10	M10	M10

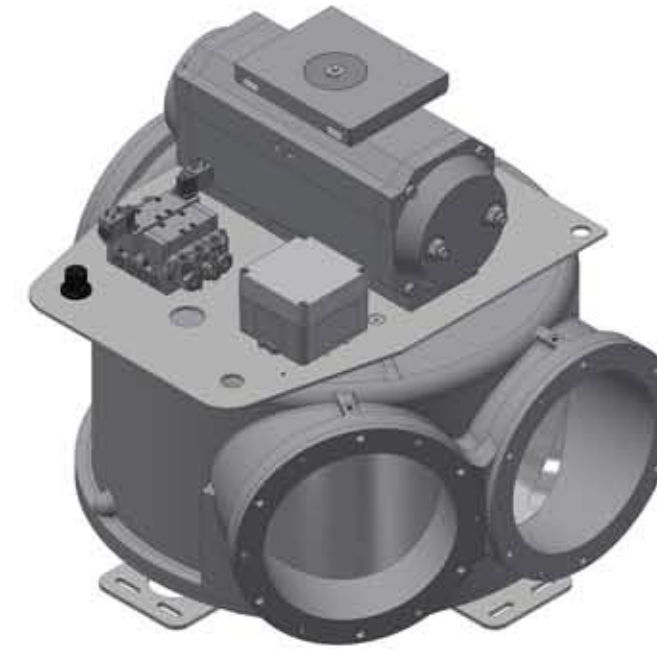

**JUNCTION BOX**

**BOX MICRO  
MULTI VOLTAGE**



**MECHANICAL  
SWITCHES  
ONLY 24 VDC**

FLEXIBLE PIPE DIVERTER VALVES are designed to divert granules, powders and pellets from one way to two ways and vice versa.

The self-cleaning gasket and inline quick repair system ensure VDF valves a long durability.



### APPLICATIONS

- DILUTE PHASE AND VACUUM
- POWDER
- GRANULE
- EXCELLENT FOR SUGAR&COFEE BEANS
- DIVERTERS AND CONVERGES

### DESIGN

- SIZE: FROM DN80, TO DN200
- BODY: PAINTED CARBON STEEL SS304 OR SS316L
- INNER PIPE: SS304 OR SS316L SPECIAL MATERIAL FOR HARD APPLICATION
- OUTLET SEAL GROUP: SLIDING UNIT + CONVEX UNIT MADE OF ALUMINUM AND POLIZENE
- DRIVE: CYLINDER COMPLETE OF ELECTROVALVE, DOUBLE SOLENOID AND LIMIT SWITCH

### FEATURES

- PRESSURE: 1 BAR
- TEMPERATURE: MAX 100 °C
- MINIMUM MAINTANANCE
- SIMPLE CONTROL
- FLY SWITCH
- QUICK REPAIR IN LINE

### OPTIONALS

- SMOOTH CONTACT SURFACE
- NO PRODUCT DAMAGE
- SPECIAL EXECUTION FOR ABRASIVE PRODUCT
- SPECIAL PIPE ON REQUEST FOR SPECIAL APPLICATION
- HIGH TEMPERATURE VERSION
- CHOICE OF PIPING COUPLING
- SIZE ON REQUEST



TOP VIEW

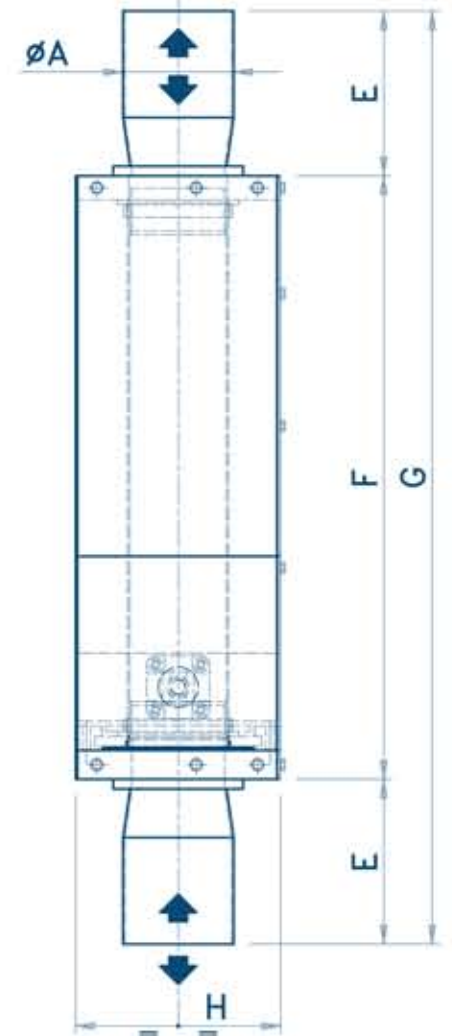
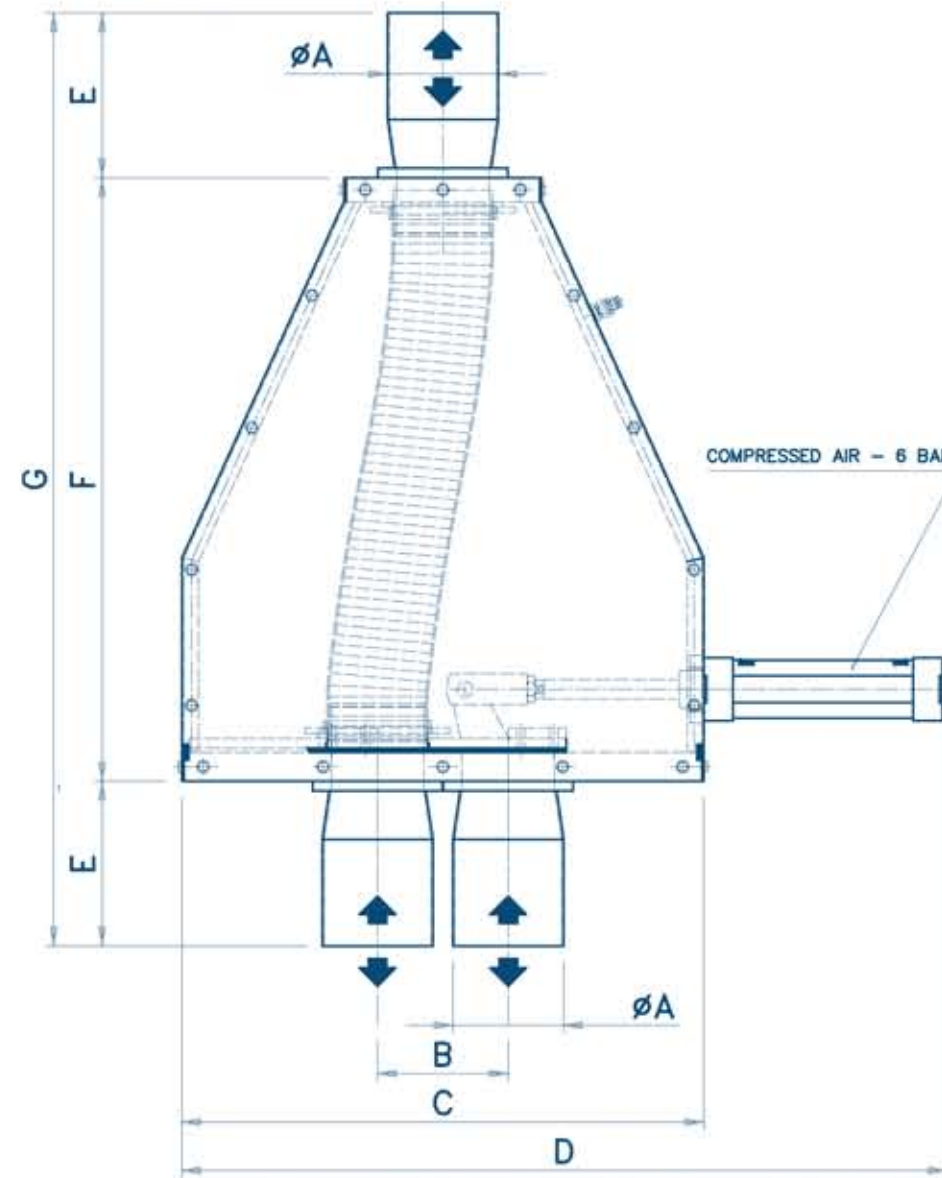

SIDE VIEW

	A	B	C	D	E	F	G	H
80	88,9	115	450	680	170	625	965	200
100	114,3	135	540	790	170	625	965	215
125	139,7	165	650	930	170	660	1000	250
150	168,3	190	730	1040	170	700	1040	265
200	219,1	240	950	1300	170	750	1090	320

BROCHURE



COMPLIANCE



II 3D IIC T135°C Dc X

RIGID PIPE DIVERter VALVES are designed to divert granules, powders and pellets from one way to two ways.

The unique design of VDP prevents any damage of product under medium pressure thanks to pressurized gasket at inlet and outlet spouts. It also reduces the maintenance thanks to a Quick Repair inline.



### APPLICATIONS

- DILUTE PHASE AND VACUUM
- POWDER
- GRANULE
- PELLETS
- DIVERterS

### DESIGN

- SIZE: FROM DN80, TO DN100
- BODY: PAINTED CARBON STEEL  
SS304 OR SS316L
- INNER PIPE: SS304 OR SS316L  
SPECIAL MATERIAL FOR HARD APPLICATION
- INLET SEAL GROUP: SEMISPHERE MADE  
OF NOVATRON + PRESSURIZED SEAL
- DRIVE: CYLINDER

### FEATURES

- PRESSURE: 2,5 BAR
- TEMPERATURE: MAX 100 °C
- LONG LIFE FOR SEAL SELF-CLEANING
- QUICK REPAIR IN LINE
- FLY SWITCH

### OPTIONALS

- MATERIAL ACCORDING WITH EC1935/2004
- SPECIAL EXECUTION FOR  
ABRASIVE PRODUCT
- SPECIAL PIPE ON REQUEST  
FOR SPECIAL APPLICATION
- SPECIAL EXECUTION FOR  
DIRECT FITTING AT PIPING
- HIGH TEMPERATURE VERSION
- ADAPTOR KIT
- HAND WHEEL
- PROXIMITY SWITCH
- SIZE ON REQUEST
- 3 WAYS VERSION

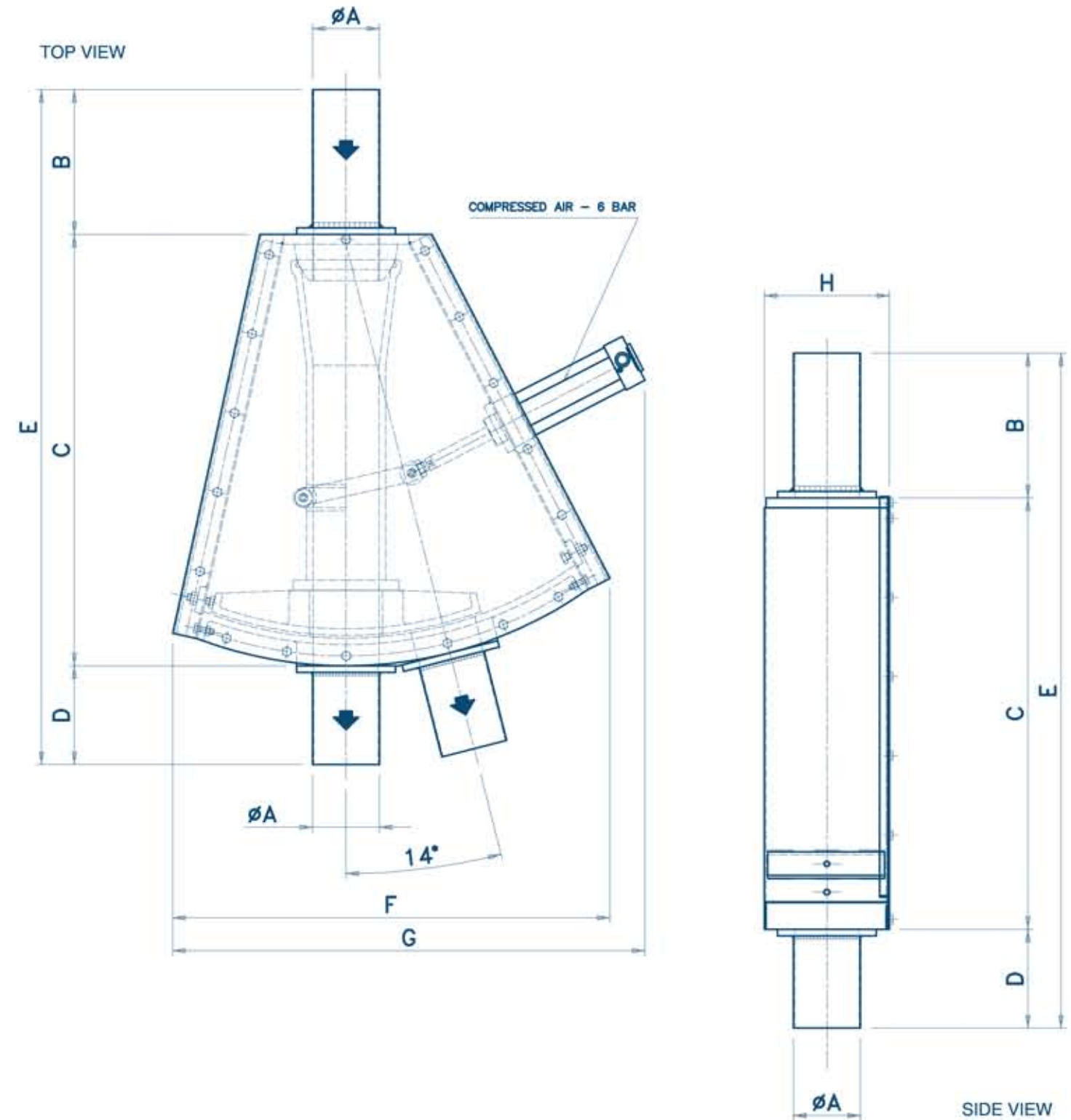

	A	B	C	D	E	F	G	H
50	60,3	100	430	70	610	425	530	172
80	88,9	150	440	150	955	665	715	190
100	101,6	220	655	150	1025	665	715	190



COMPLIANCE



II 3D IIC T135°C Dc X

GRAVIMETRIC DIVERTER VALVES are designed to divert granules, powders and pellets from one way to two ways.

Thanks to two different special executions they are also used for abrasive products and in dairy making DTG2 is an universal valve suitable for all kinds of applications. Thanks to the wide range of accessories, DTG2 can meet all customer's need.



## APPLICATIONS

- GRAVIMETRIC DISCHARGE
- POWDER
- GRANULE
- PELLETS
- DIVERTERS
- MOCA – EC1935/2004

## DESIGN

- SIZE: DN150, DN200, DN 250
- BODY: CARBON STEEL, ALUMINIUM, SS304 OR SS316L
- FLAP: PAINTED CARBON STEEL, SS304 OR SS316L
- SEAL: TEFLON
- OPERATION: CYLINDER OR MANUAL

## FEATURES

- PRESSURE: ATM
- TEMPERATURE: MAX 100 °C
- FLY SWITCH
- RUGGED DESIGN
- LONG LIFE

## OPTIONALS

- SPECIAL EXECUTION FOR ABRASIVE PRODUCT
- INNER POLISHED TREATMENT
- MATERIAL ACCORDING WITH EC1935/2004
- VARIOUS CHEMICAL TREATMENT ON BODY/FLAP
- HIGH TEMPERATURE VERSION
- INSPECTION DOOR WITH SAFETY KEY
- INNER CONE FOR FLOWRATE REDUCTION
- SIZE ON REQUEST
- KIT CONNECTING PIPE

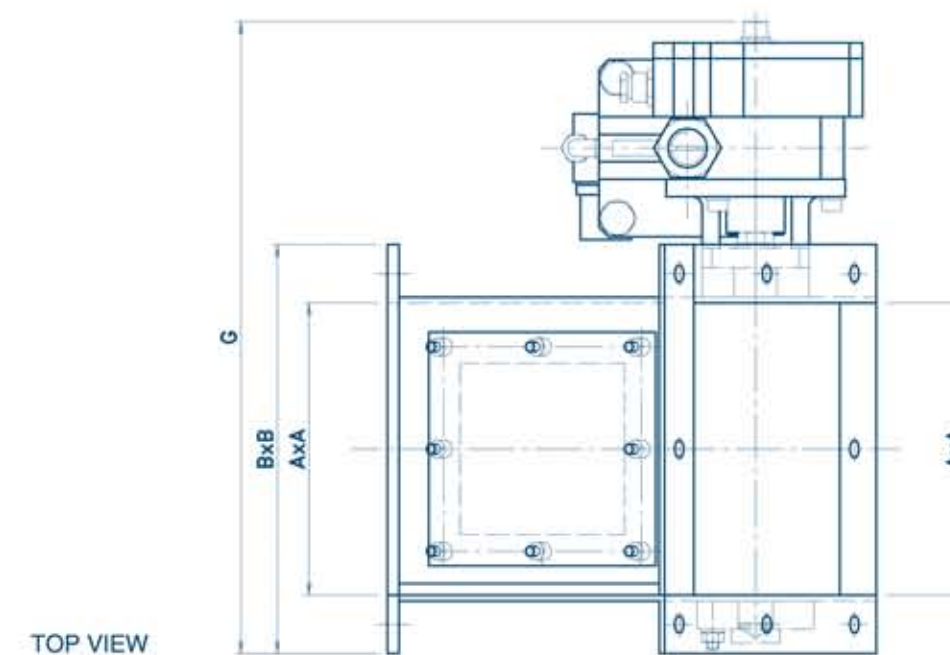
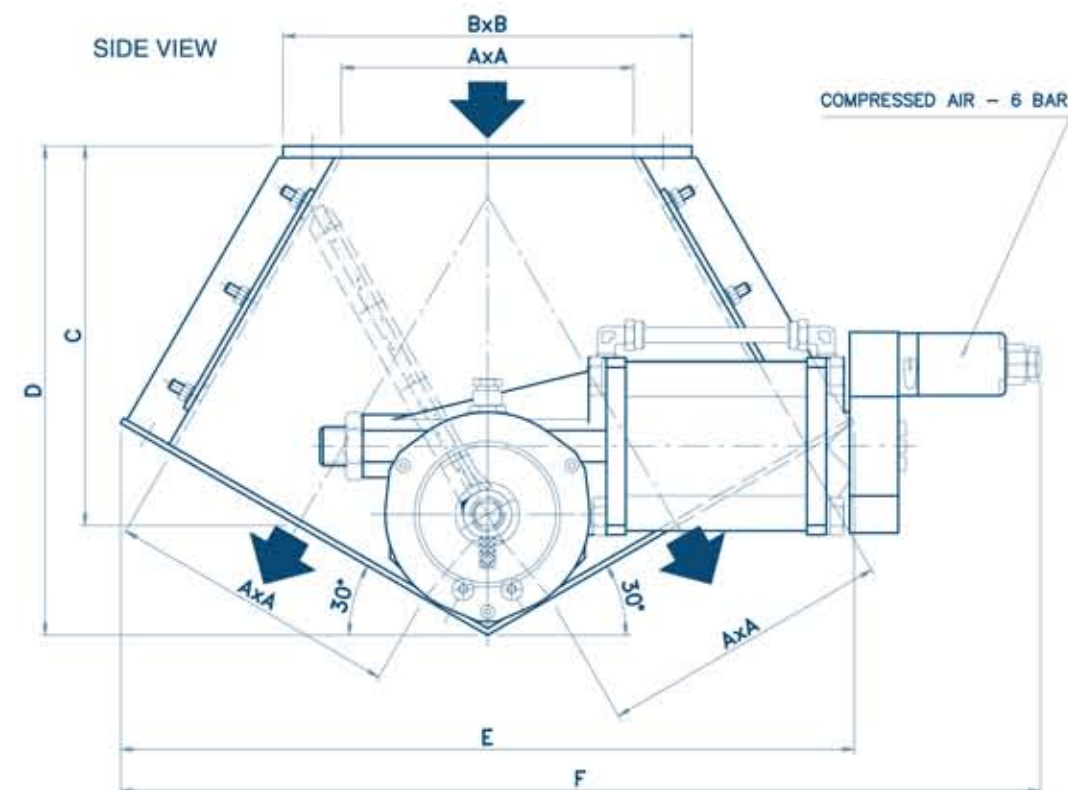

	A	B	C	D	E	F	G	WEIGHT
150	150	210	195	250	375	470	325	Kg -
200	200	266	275	340	480	645	380	Kg -
250	250	316	325	400	565	700	430	Kg -

BROCHURE



COMPLIANCE



II 3D IIC T135°C Dc X

# DTG3 3 WAYS GRAVIMETRIC

GRAVIMETRIC DIVERTER VALVES are designed to divert granules, powders and pellets from one way to three ways.

Thanks to two different special executions they are also used for abrasive products and in dairy making DTG3 is an universal valve suitable for all kinds of applications with many accessories that match the customer's needs.



## APPLICATIONS

- GRAVIMETRIC DISCHARGE
- POWDER
- GRANULE
- PELLETS
- DIVERTERS
- MOCA - EC1935/2004

## DESIGN

- SIZE: DN150, DN200, DN 250
- BODY: CARBON STEEL, ALUMINIUM, SS304 OR SS316L
- FLAP: PAINTED CARBON STEEL, SS304 OR SS316L
- SEAL: FELT
- OPERATION: CYLINDER OR MANUAL

## FEATURES

- PRESSURE: ATM
- TEMPERATURE: MAX 100 °C
- FLY SWITCH
- RUGGED DESIGN
- LONG LIFE

## OPTIONALS

- SPECIAL EXECUTION FOR ABRASIVE PRODUCT
- INNER POLISHED TREATMENT
- MATERIAL ACCORDING WITH EC1935/2004
- VARIOUS CHEMICAL TREATMENT ON BODY/FLAP
- HIGH TEMPERATURE VERSION
- INSPECTION DOOR WITH SAFETY KEY
- INNER CONE FOR FLOWRATE REDUCTION
- SIZE ON REQUEST
- KIT CONNECTING PIPE

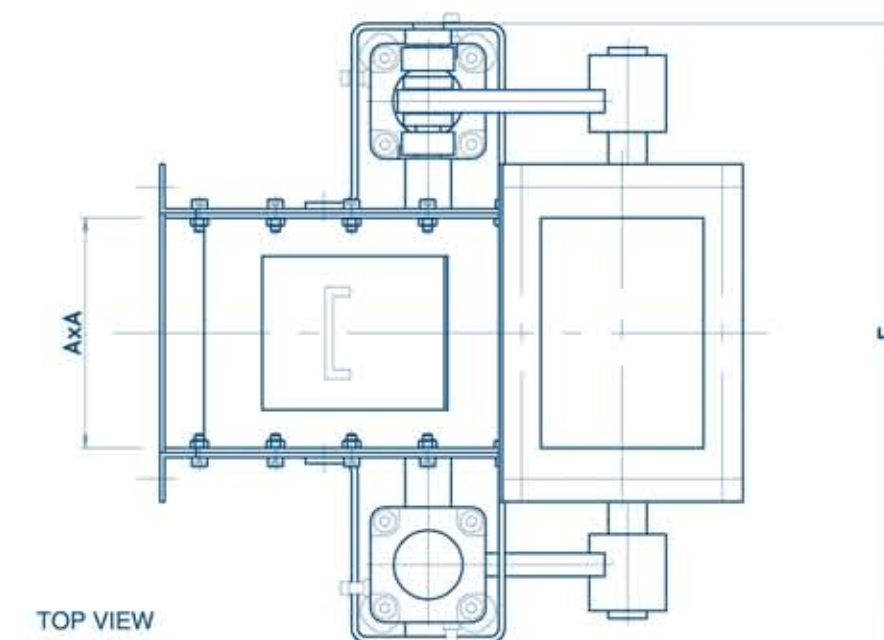
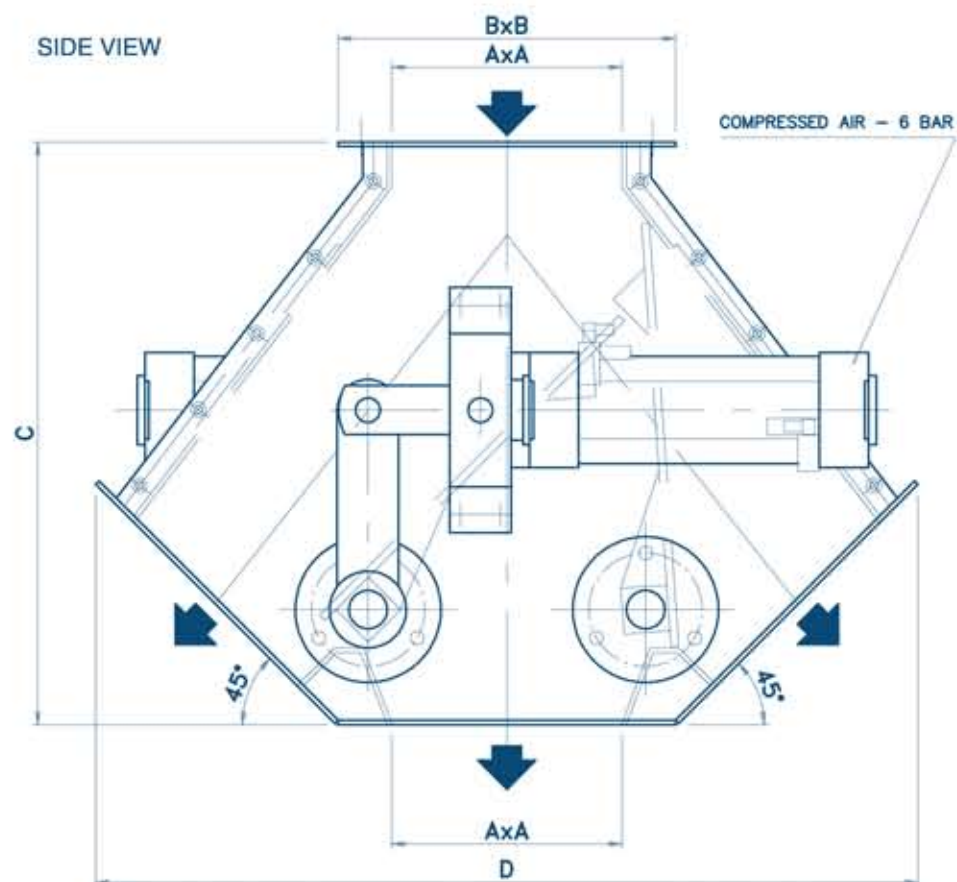

	A	B	C	D	E	WEIGHT
150	150	220	450	655	455	Kg -
200	200	270	450	655	455	Kg -
250	250	320	500	775	505	Kg -

BROCHURE



COMPLIANCE



II 3D IIC T135°C Dc X

# SGA1 SINGLE CYLINDER KNIFE VALVE

SLIDE GATE VALVES SGA1 are designed to shut off the flow of product from outlets of dry bulk storage bins, silos, conveyors and other discharge points.

SGA1 is used where dust sealing is requested. The self-calibrated spring ensures the valve a long durability and reduces SGA1 wear and tear. Slide gate valve is suitable for the most demanding applications on market.



## APPLICATIONS

- GRAVIMETRIC FLOW
- POWDER
- GRANULE
- PELLETS
- MOCA – EC1935/2004

## DESIGN

- SIZE: DN 150, DN 200, DN 250
- BODY: CASTING ALUMINIUM
- BLADE: SS304/SS316L
- MAIN SEAL: NOVATRON
- OPERATION: SINGLE CYLINDER, HANDWHEEL

## OPTIONALS

- SPECIAL EXECUTION FOR ABRASIVE PRODUCT
- MATERIAL ACCORDING WITH EC1935/2004
- VARIOUS CHEMICAL TREATMENT ON BODY/FLAP
- VARIOUS SEAL MATERIAL
- HIGH TEMPERATURE VERSION
- CUSTOM SIZE

## FEATURES

- PRESSURE: ATM, 1 BAR
- TEMPERATURE: MAX 100 °C
- RUGGED DESIGN
- LONG LIFE

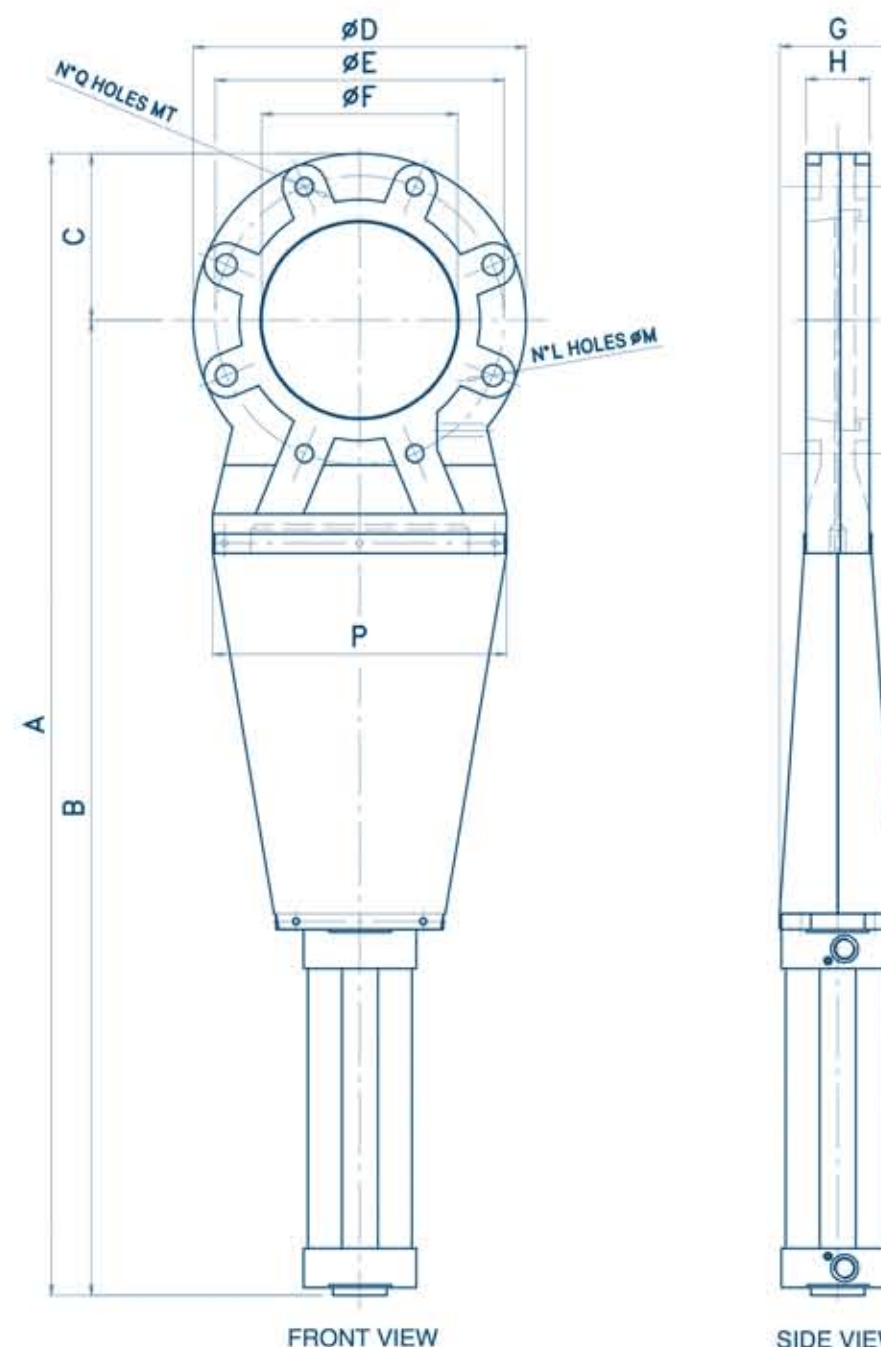

	A	B	C	D	E	F	G	H	L x ØM	P	Q x MT
150	935	795	140	280	Ø240	Ø153	115	65	4 x Ø22	270	4 x M20
200	1130	960	170	340	Ø295	Ø200	115	65	4 x Ø22	300	4 x M20
250	1325	1130	195	390	Ø350	Ø254	140	65	6 x Ø22	360	6 x M20

BROCHURE



COMPLIANCE



II 3D IIC T135°C Dc X

# SGA2 DOUBLE CYLINDER KNIFE VALVE

SLIDE GATE VALVES SGA2 are designed to shut off the flow of product from outlets of dry bulk storage bins, silos, conveyors and other discharge points. It is recommended for hopper with weighing cells and dosing units since it can avoid any reading error.

SGA2 is used where dust sealing is requested. The self-calibrated spring ensures the valve a long durability and reduces SGA2 wear and tear. Slide gate valve is suitable for the most demanding application on market. Its compact size allows a wide variety of installations.



## APPLICATIONS

- GRAVIMETRIC FLOW
- POWDER
- GRANULE
- PELLETS
- MOCA – EC1935/2004

## DESIGN

- SIZE: DN 150, DN 200, DN 250
- BODY: CASTING ALUMINIUM
- BLADE: SS304/SS316L
- MAIN SEAL: NOVATRON
- OPERATION: DOUBLE CYLINDER

## FEATURES

- PRESSURE: ATM, 1 BAR
- TEMPERATURE: MAX 100 °C
- RUGGED DESIGN
- LONG LIFE

## OPTIONALS

- SPECIAL EXECUTION FOR ABRASIVE PRODUCT
- MATERIAL ACCORDING WITH EC1935/2004
- VARIOUS CHEMICAL TREATMENT ON BODY/FLAP
- VARIOUS SEAL MATERIAL
- HIGH TEMPERATURE VERSION
- CUSTOM SIZE

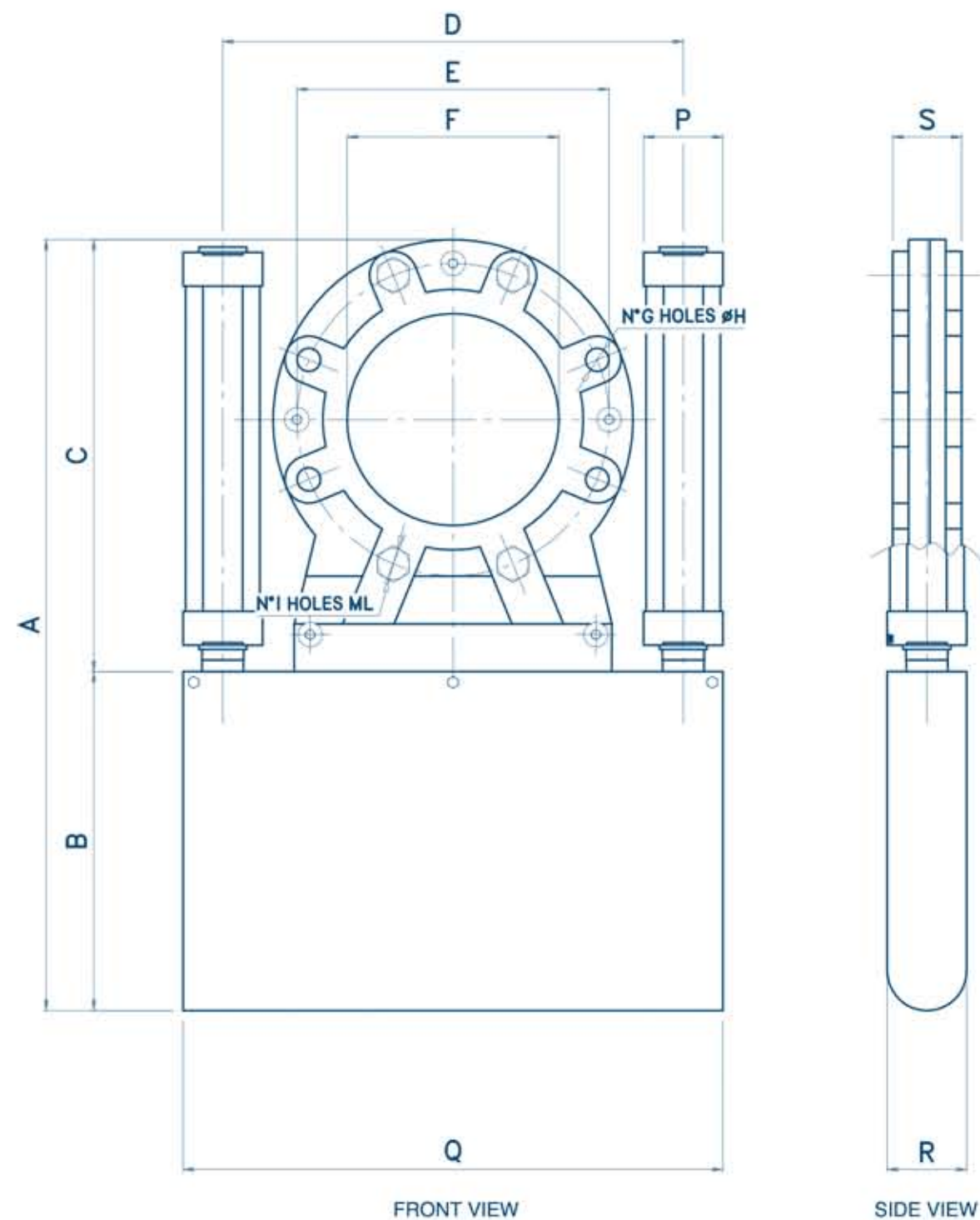

	A	B	C	D	E	F	G x H	I x ML	P	R	S	Q
150	670	295	375	386	Ø240	Ø153	4 x Ø22	4 x M20	95	112	65	485
200	770	345	425	441	Ø295	Ø200	4 x Ø22	4 x M20	95	112	65	540
250	895	395	500	515	Ø350	Ø254	6 x Ø22	6 x M20	115	112	65	640

BROCHURE



COMPLIANCE



II 3D IIC T135°C Dc X



SLIDE GATE VALVES SGB are designed for shutting off the flow of product and dosing the product during discharge.

SGB, thanks to a two opposite cylinders, sets the dosing through the double blades having always a free opening. Moreover its compact design allows number of applications from outlets of dry bulk storage bins, silos, conveyors and other discharge points.

SGB is used where dust sealing is requested. The self-calibrated spring ensures the valve a long durability and reduces SGB wear and tear. SGB is suitable for the most demanding application on market.



### APPLICATIONS

- GRAVIMETRIC FLOW
- POWDER
- GRANULE
- PELLETS
- MOCA – EC1935/2004

### DESIGN

- SIZE: DN 200
- BODY: ALUMINIUM
- BLADE: SS304/SS316L
- MAIN SEAL: NOVATRON
- OPERATION: DOUBLE CYLINDER

### FEATURES

- PRESSURE: ATM, 1 BAR
- TEMPERATURE: MAX 100 °C
- RUGGED DESIGN
- LONG LIFE

### OPTIONALS

- SPECIAL EXECUTION FOR ABRASIVE PRODUCT
- MATERIAL ACCORDING WITH EC1935/2004
- VARIOUS CHEMICAL TREATMENT ON BODY/FLAP
- VARIOUS SEAL MATERIAL
- HIGH TEMPERATURE VERSION
- CUSTOM SIZE

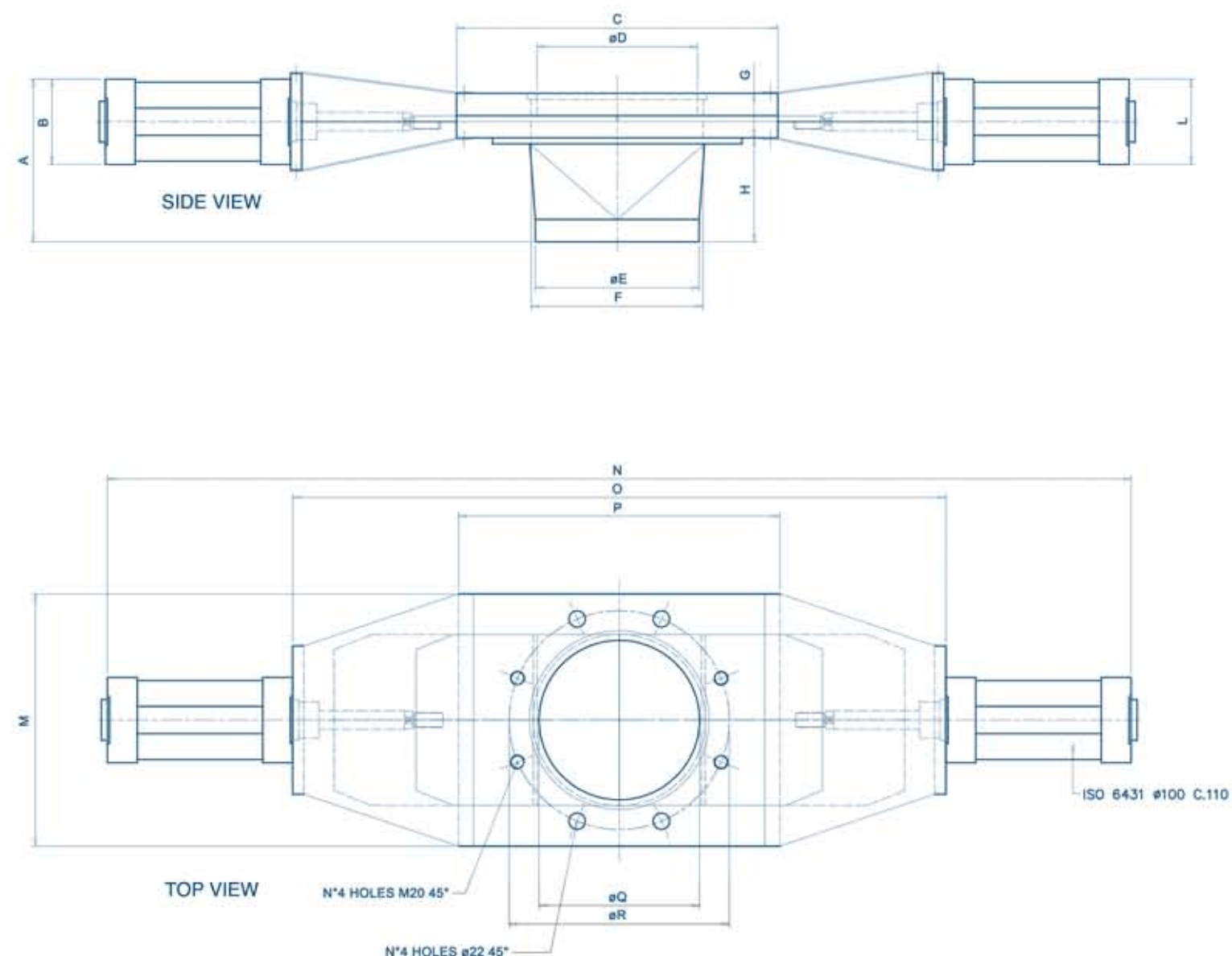

	A	B	C	ØD	ØE	F	G	H	L	M	N	O	P	ØQ	ØR
200	220	115	430	215	219,1	230X230	60	140	115	340	1370	875	430	215	295

BROCHURE



COMPLIANCE



II 3D IIC T135°C Dc X

SLIDE GATE VALVES SGM are designed for shutting off the material from hoppers, silos and rotary valves when maintenance of downstream equipment is requested.

SGM is suitable for a range of application thanks to its compact design. The blade self-cleaning after each opening ensures the valve a long durability.



### APPLICATIONS

- GRAVIMETRIC FLOW
- POWDER
- GRANULE
- PELLETS
- MOCA – EC1935/2004

### DESIGN

- SIZE: DN 150, DN 200, DN 250
- BODY: CASTING ALUMINIUM
- BLADE: SS304/SS316L
- OPERATION: MANUAL

### FEATURES

- PRESSURE: ATM
- TEMPERATURE: MAX 100 °C
- NARROW PROFILE
- FREE OPENING
- HORIZONTAL AND VERTICAL INSTALLATION
- LONG LIFE

### OPTIONALS

- SPECIAL EXECUTION FOR ABRASIVE PRODUCT
- MATERIAL ACCORDING WITH EC1935/2004
- CUSTOM SIZE

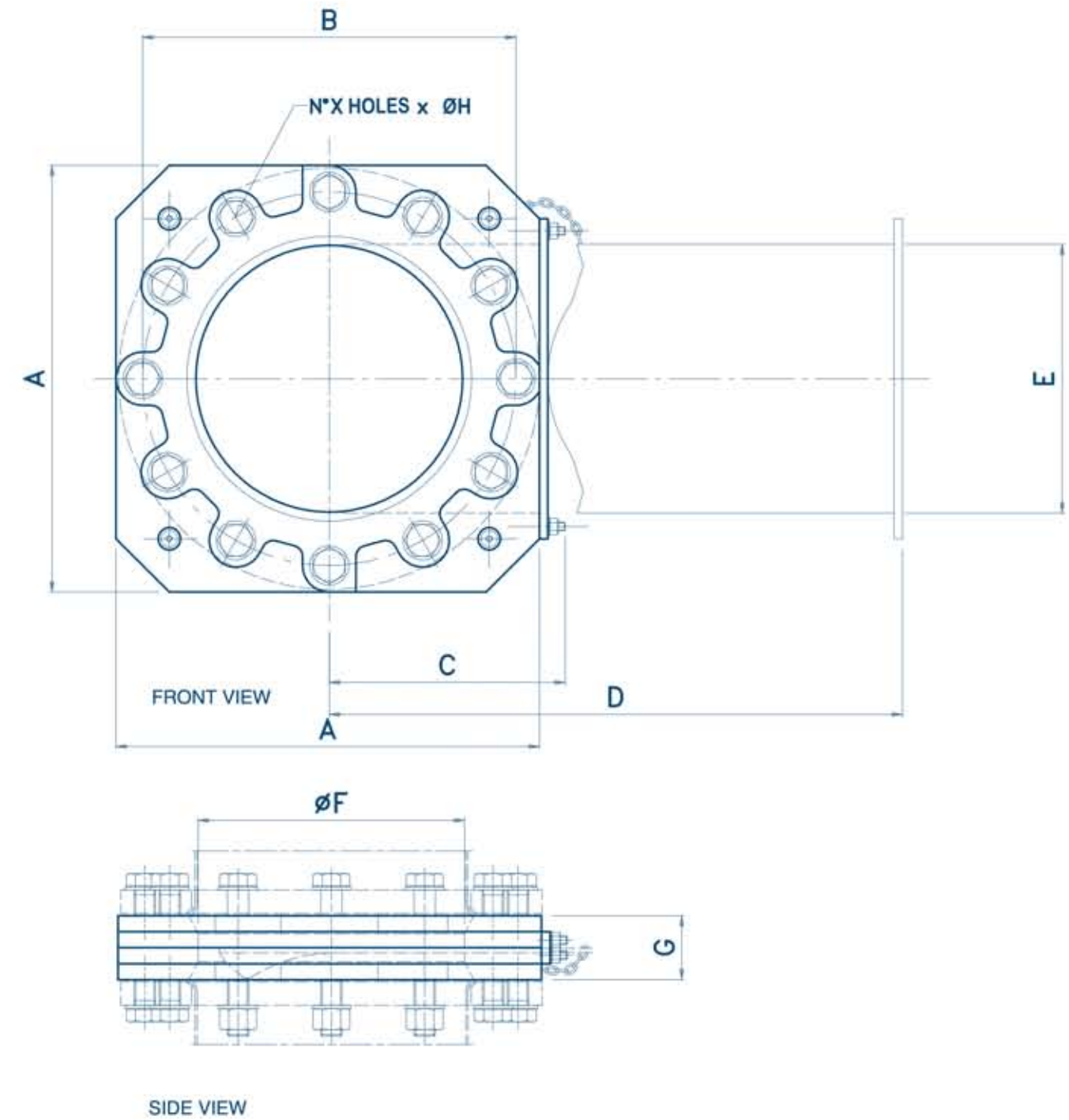

	A	B	C	D	E	F	G	I x ML
150	285	Ø240	180	406	160	Ø156	58	8 x Ø22
200	340	Ø295	208	484.5	205	Ø200	64	8 x Ø22
250	400	Ø350	237	568	264	Ø250	60	12 x Ø22

BROCHURE



COMPLIANCE



OVER UNDER PRESSURE RELIEF VALVES are designed to prevent any risk of explosion or implosion, thanks to the calibration of springs which release an inner metal disk thus assuring the air venting, in case of over/under pressure condition.

The valve is connected through a flange to hopper and silo. Its major advantage is to have a simple & easy installation. This device may be calibrated for sundry pressure and/or underpressure levels by setting the preloading of springs.

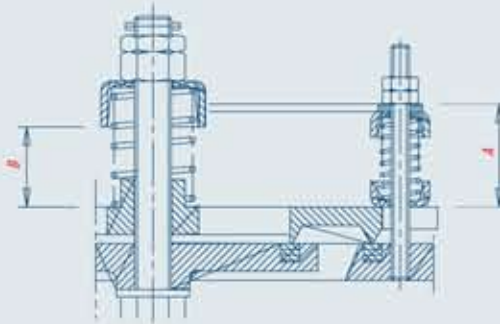

### APPLICATIONS

- FILLING
- STORING
- SILO
- HOPPER
- BINS/TANKS

### DESIGN

- FLANGING: DN 250 PN 16 (4 HOLES)
- HOUSING: SS304
- DISK: SS304

### FEATURES

- DESIGN PRESSURE: +100/- 50 mbar
- WORKING PRESSURE: MAX +45/-20 mbar
- DESIGN TEMPERATURE: -20°/+200° C
- WORKING TEMPERATURE: -10°/+150° C
- MIN SETTING RANGE: +8/-5 mbar

BROCHURE



COMPLIANCE

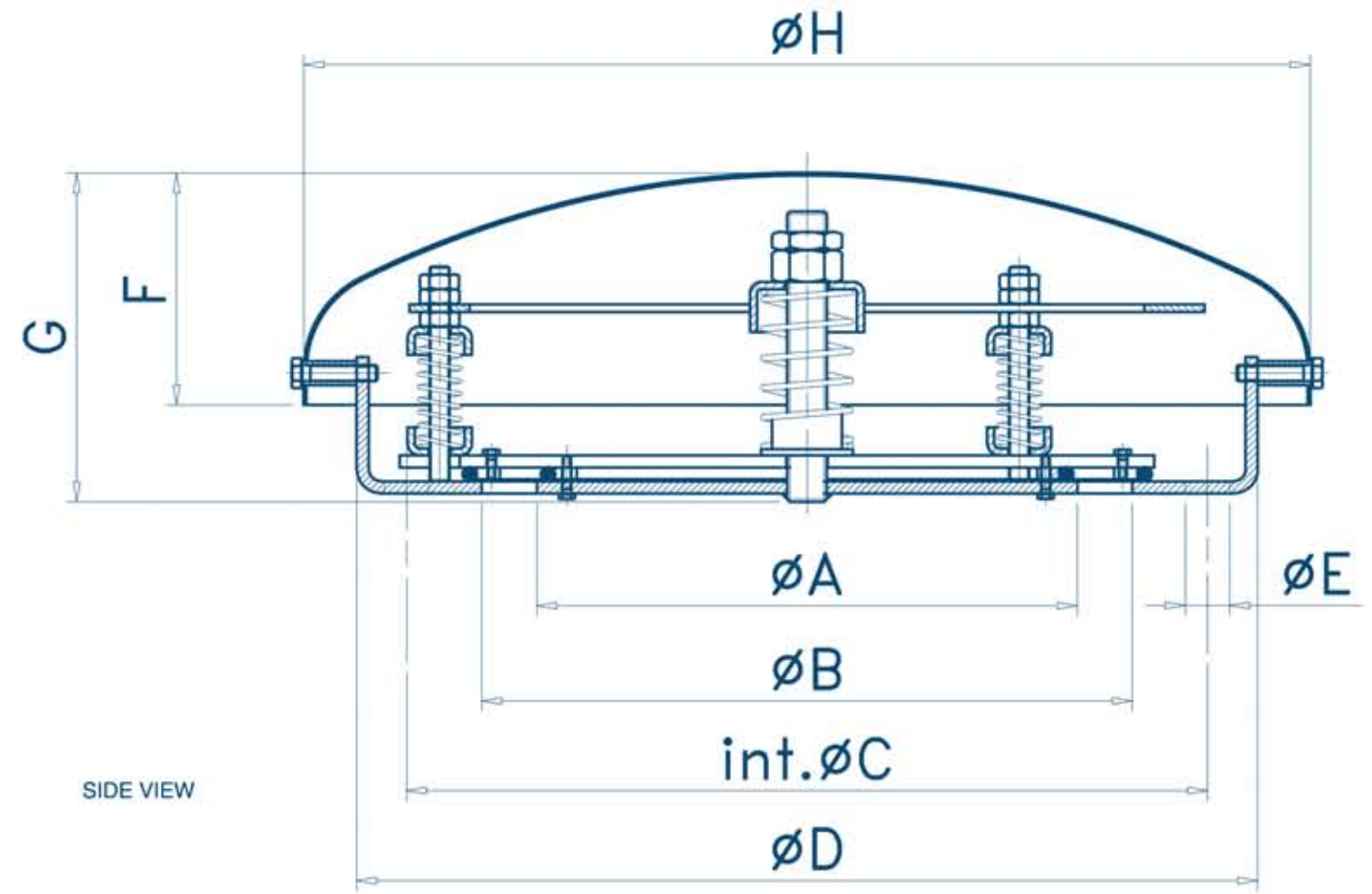
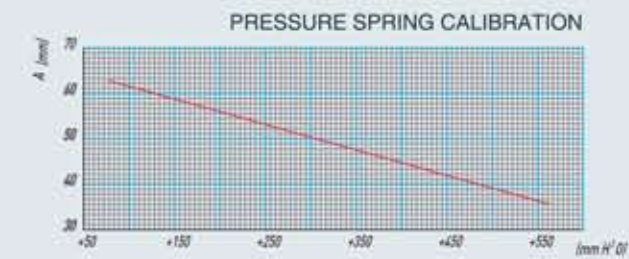

FLANGING	HOLES	ØA	ØB	ØC	ØD	ØE	F	G	ØH
250 PN16	4	215	270	355	405	25	115	165	500
300 PN10	8	270	325	400	450	22	115	165	500

