

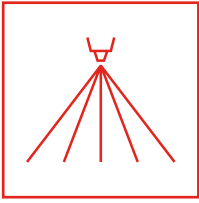

Liquid painting booths

Euro THERM
SINCE 1958
PAINTING INSTALLATIONS





Liquid painting booths

Eurotherm manufactures liquid painting booths with dry or water filtration **made to measure to resolve any problem** related to the processing of objects of all shapes and sizes.

Our booths are designed and **built according to your actual needs**, the pieces to be treated and the place where they will be placed.

The booths can be **customised according to your requirements:**

- Suction wall with double filtration + activated carbon.
- Walls and roof made of pre-insulated painted panels.
- Internal LED lighting lamps integrated into the walls and roof.
- Pre-insulated industrial manual folding door.
- Air handling unit for controlled temperature and humidity.
- Motorised roller shutter door.
- Automatic roof opening for overhead travelling crane passage.
- Lifting platforms.

The aim of our spray booths is simple:

- To achieve the desired **quality**.
- The **safety** of the paint worker.
- **Compliance with the environmental regulations**.

Our spray booths are made taking these needs into consideration, preventing dust or other impurities from entering the booth and optimising the work cycle with a view to saving energy for the company.

The **dry painting booths** are particularly suitable **for large components** and with a low production rate and the water wash booths are developed for the painting of **large batches at high production rates**.

DRY FILTRATION BOOTHS

We create painting booths suitable for use with water-based or solvent-based paints. From the simple suction wall for manual painting, to pressurised booths with controlled temperature and humidity.

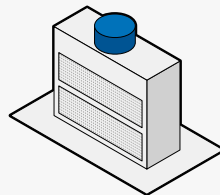

➤ **Suction wall** with the 1st stage of filtration in corrugated cardboard and the 2nd stage of filtration in fiber glass

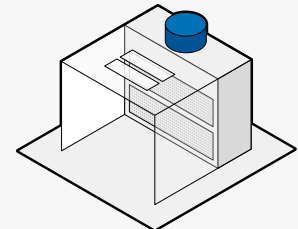

➤ **Suction wall with extended walls and roof** with walls and roof in galvanised sheet with lights



➤ Large painting booths

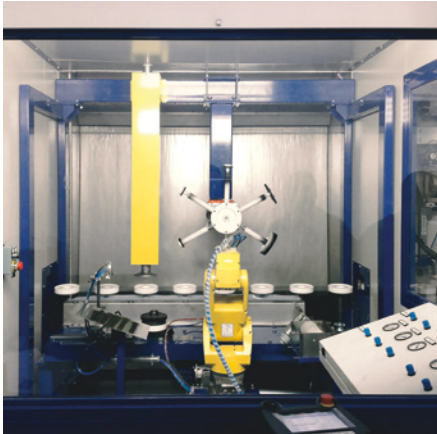

➤ Water wash painting booths



➤ Pressurised spray booths

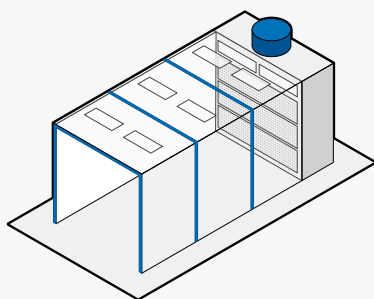

➤ **Spray booth with canopy**
with walls and roof made of pre-insulated painted panels with lights

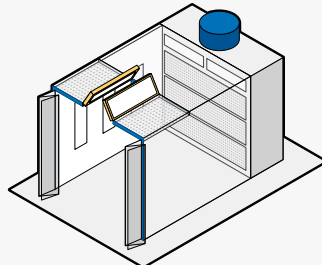

➤ **Oblique air flow spray booth** with filtered roof air inlet and folding door

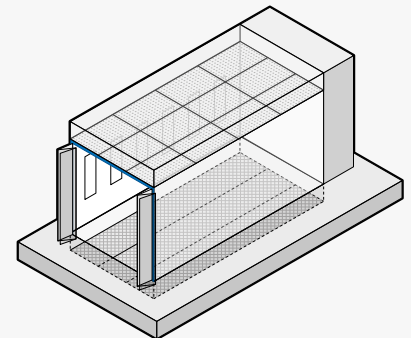

➤ **Pressurised spray booth** with filtered air inlet plenum and floor extraction



PAINTING INSTALLATIONS

ITALY | Turin

Eurotherm S.p.A

Turin Headquarter
Via Pisa, 78
10088 Volpiano (TO)
T. +39 011 98 23 500
M. info@eurotherm.eu

ITALY | Verona

Eurotherm S.p.A

Verona Office
Via Madonna, 1
37051 Bovolone (VR)
T. +39 045 71 00 209
M. info@eurotherm.eu

FRANCE

Eurotherm France S.A.S.

17 Z.A. de Vignerolles
13330 Pélissanne
T. +33 (0) 4 90 55 20 75
M. france@eurotherm.eu

GERMANY - AUSTRIA - SWITZERLAND

Eurotherm Oberflächentechnik GmbH

Schulweg 6
D-72488 Sigmaringen
T. +49 (0) 7571/92795-10
F. +49 (0) 7571/92795-99
M. contact@eurotherm.eu

Since 1958 we have been manufacturing customised systems to meet the painting needs of any company: from small businesses to large industries.

For the Italian and international market we design, build and install painting systems, overseeing every phase of the industrial process.

From pre-treatment operations, such as washing and shot blasting, to the final finishing process: **the Eurotherm systems apply the most efficient and technological processes, to ensure a constant high-level result.**



SHOT
BLASTING



WASHING



LIQUID
PAINTING



POWDER
PAINTING

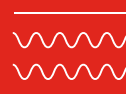

CURING