

Automatic washing cells and tunnels

EuroTHERM
SINCE 1958
PAINTING INSTALLATIONS

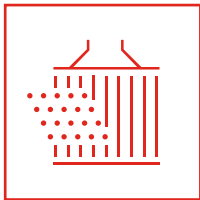



Automatic washing cells and tunnels

This type of washing system is **the most used solution** in the world of industrial washing **when a high production rate is required**.

They are **all made of stainless steel** to ensure **maximum resistance from the chemicals liquids** and to increase the longevity of the machinery.

STRENGTHS

- The minimisation of contamination between the baths of each phase.
- Optimisation of the chemicals used.
- No dispersion of chemical products in the sewer with consequent reduction of the environmental impact.

The tunnels and washing cells are designed to perform surface treatment of the pieces involving **up to 6 phases**:

- **1st Phase:** degreasing with hot phosphodegreasing solution (50/60°C).
- **2nd Phase:** first rinse with mains water.
- **3rd Phase:** second rinse with mains water.
- **4th Phase:** rinsing with recirculated reverse osmotic water.
- **5th Phase:** pure reverse osmotic water.
- **6th Phase:** nanotechnological passivation.

For **each washing phase** there is a **dedicated accumulation tank** which feeds the spray nozzles in a continuous and automatic cycle by means of a reverse cascade.

Inside the **multi-metal washing cell** it is possible to carry out **two different pre-treatment processes** based on the type of material to be treated.

For example, it is possible **to pre-treat steel or aluminium**, each with its own **dedicated washing cycle**. The cell is in fact designed in such a way as to **limit as much as possible the risk of contamination** of liquids during the rinsing phases.

AUTOMATIC CELLS AND TUNNELS

They are designed to operate with hot degreasing with the pieces **in continuous movement, thus combining chemical, thermal and mechanical action**, to guarantee excellent results and to eliminate all traces of impurities or residual dirt.

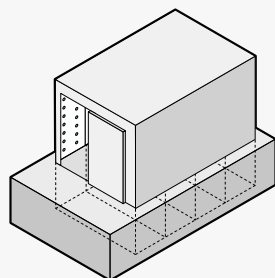

➤ **Washing cell with civil works**
Hot degreasing, 2 rinses, reverse osmosis + passivating rinse

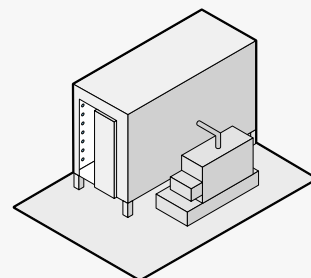

➤ **Washing cell without civil works**
Hot degreasing, 2 rinses, reverse osmosis + passivating rinse



➤ Automatic washing cells



➤ Multi metal washing cell

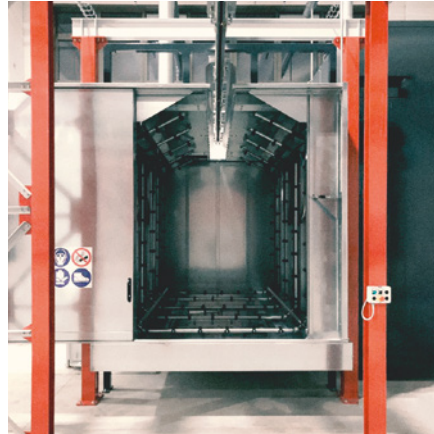

➤ Ecojet washing cells

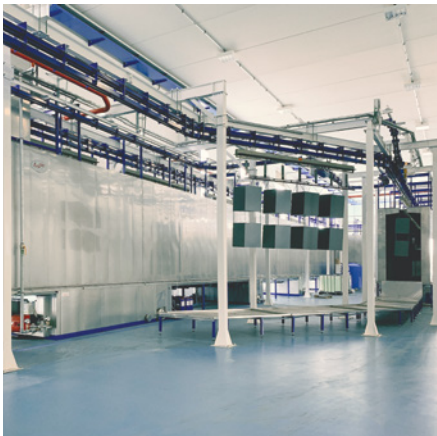

➤ Automatic washing tunnels

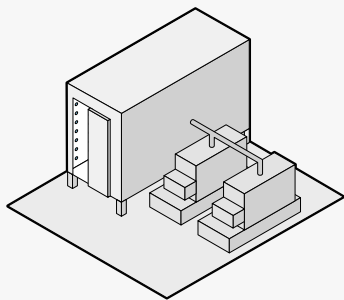

➤ **Multi metal washing cell for steel + aluminium** equipped with double tanks to perform two separate washing processes

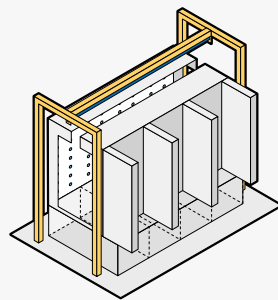

➤ **Step-by-step washing tunnel**
Hot degreasing, 2 rinses
+ reverse osmosis rinse

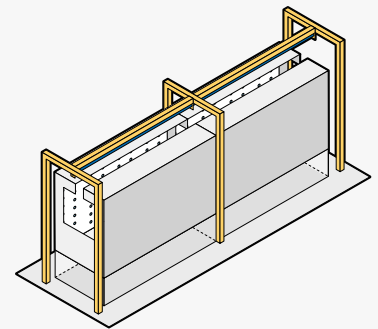

➤ **Step-by-step washing tunnel**
Hot degreasing, 2 rinses
+ reverse osmosis rinse



PAINTING INSTALLATIONS

ITALY | Turin

Eurotherm S.p.A

Turin Headquarter
Via Pisa, 78
10088 Volpiano (TO)
T. +39 011 98 23 500
M. info@eurotherm.eu

ITALY | Verona

Eurotherm S.p.A

Verona Office
Via Madonna, 1
37051 Bovolone (VR)
T. +39 045 71 00 209
M. info@eurotherm.eu

FRANCE

Eurotherm France S.A.S.

17 Z.A. de Vignerolles
13330 Pélissanne
T. +33 (0) 4 90 55 20 75
M. france@eurotherm.eu

GERMANY - AUSTRIA - SWITZERLAND

Eurotherm Oberflächentechnik GmbH

Schulweg 6
D-72488 Sigmaringen
T. +49 (0) 7571/92795-10
F. +49 (0) 7571/92795-99
M. contact@eurotherm.eu

Since 1958 we have been manufacturing customised systems to meet the painting needs of any company: from small businesses to large industries.

For the Italian and international market we design, build and install painting systems, overseeing every phase of the industrial process.

From pre-treatment operations, such as washing and shot blasting, to the final finishing process: **the Eurotherm systems apply the most efficient and technological processes, to ensure a constant high-level result.**



SHOT
BLASTING



WASHING



LIQUID
PAINTING



POWDER
PAINTING

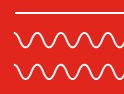

CURING